



USE AND MAINTENANCE MANUAL



MB-C50
BF60.1
BF70.2

BF90.3 S2
BF90.3 S2 HD

BF120.4 S2
BF120.4 S2 HD

- COPY TRANSLATED FROM THE ORIGINAL -



MB-C50 - BF60.1 - BF70.2 - BF90.3 S2 - BF90.3 S2 HD - BF120.4 S2 - BF120.4 S2 HD

SUMMARY

INTRODUCTION	4
1 GENERAL INFORMATION	5
1.1 MANUFACTURER'S IDENTIFICATION DATA.....	5
1.2 TECHNICAL SUPPORT.....	5
1.3 MACHINE IDENTIFICATION AND CE MARKING.....	5
1.4 NORMATIVE REFERENCES.....	7
1.5 WARRANTY.....	7
1.6 STRUCTURE OF THE MANUAL.....	9
1.6.1 PURPOSE OF THE MANUAL.....	9
1.6.2 IMPORTANCE OF THE MANUAL.....	9
1.6.3 CONTENT OF THE MANUAL.....	9
1.6.4 ADDRESSEES.....	9
1.6.5 RESPONSIBILITY OF THE USER.....	10
1.6.6 CONSERVATION OF THE MANUAL.....	10
1.6.7 SYMBOLS AND DEFINITIONS USED IN THE MANUAL.....	10
2 SAFETY REGARDING THE MACHINE	11
2.1 GENERAL SAFETY WARNINGS.....	11
2.1.1 ESSENTIAL CHARACTERISTICS OF THE MACHINE TOOL.....	11
2.2 FORESEEN USE.....	13
2.3 UNFORESEEN USE.....	14
2.4 USE OF PERSONAL PROTECTIVE EQUIPMENT (PPE).....	15
2.5 ADHESIVE SAFETY LABELS.....	16
2.6 ADDITIONAL SAFETY DIRECTIVE.....	18
2.6.1 PROCEDURE FOR UNBLOCKING THE MATERIAL.....	18
2.6.2 RESIDUAL RISKS.....	19
2.6.3 STANDARD EQUIPMENT - KIT BOLTS.....	19
2.6.4 STABILITY OF THE MACHINES.....	20
3 TECHNICAL DESCRIPTION OF THE BUCKET CRUSHER	21
3.1 TECHNICAL DATA OF CRUSHER BUCKETS.....	21
3.1.1 OIL SPECIFICATIONS.....	21
3.2 EXCAVATOR'S HYDRAULIC SYSTEM PARAMETERS.....	21
3.3 EXCAVATOR'S HYDRAULIC REGULATION.....	22
3.4 INTERFACES.....	23
4 GENERAL DESCRIPTION	23
4.1 GENERAL DESCRIPTION.....	23
4.2 MACHINE TRANSPORT.....	23
4.2.1 MACHINE TRANSPORT: FASTENING.....	24
4.2.2 UNLOADING OF THE BUCKET CRUSHER.....	25
4.3 HYDRAULIC SYSTEM CONNECTION.....	27
5 MACHINE FUNCTIONING	28
5.1 MACHINE START-UP.....	28
5.2 INSTALLATION.....	29
5.1.1 CONNECTING THE MACHINE WITH A FIXED COUPLING.....	30
5.1.2 CONNECTING THE MACHINE WITH A QUICK COUPLING.....	31
5.3 NOISE EMITTED BY THE EQUIPMENT.....	32
5.4 ADJUSTMENT ON MACHINES.....	33
5.4.1 HYDRAULIC OIL FLOW REGULATION.....	42
5.4.2 DRAIN PIPE INSTALLATION.....	44
5.4.3 BELT'S TENSION REGULATION.....	45
6 MACHINE MAINTENANCE	49
6.1 GENERAL WARNINGS.....	49
6.2 BUCKET CRUSHER MAINTENANCE.....	50
6.2.1 PERIODICAL CHECKS.....	50
6.2.2 PERIODIC REPLACEMENT OF COMPONENTS.....	51
6.2.3 ROUTINE MAINTENANCE.....	66
7 HEAVY COMPONENTS - WEIGHT OF SINGLE COMPONENTS	67
7.1 MB-C50.....	67
7.2 BF 60.1.....	68
7.3 BF 70.2.....	69
7.4 BF 90.3 S2 - BF 90.3 S2 HD.....	70
7.5 BF 120.4 S2 - BF 120.4 S2 HD.....	71
8 MACHINE DEMOLITION	72
8.1 WASTE DISPOSAL.....	72
8.2 MACHINE DEMOLITION.....	72
HYDRAULIC SYSTEM WITH DRAINAGE.....	73-77
HYDRAULIC SYSTEM.....	78-81

INTRODUCTION

Dear Customer,

We thank you for choosing a machine of **MB S.p.A.** company, and we are pleased to provide you with this manual, which has the purpose of helping you working with the Bucket Crusher in the safest and most productive manner possible.

We kindly suggest you to read this technical information very carefully, and provide it to the people who will use the Bucket Crusher, as well as to those who will service it.

The information contained in this manual is **MB S.p.A.**'s reserved property and refers in particular to the Bucket Crusher, identified as:

Model: **MB-C50 - BF 60.1 - BF 70.2 - BF 90.3 S2 - BF 90.3 S2 HD - BF 120.4 S2 -BF 120.4 S2 HD**

Serial number:

Year of manufacturing:

Manual Identification Data

Revision:	00	21-01-2005	Cod. 01-05
Revision:	01	26-11-2006	Cod. 01-06
Revision:	02	15-12-2007	Cod. 01-07
Revision:	03	09-05-2009	Cod. 01-09
Revision:	04	17-03-2011	Cod. 01-11
Revision:	05	28-01-2012	Cod. 01-12
Revision:	06	02-04-2013	Cod. 01-13
Revision:	07	01-10-2013	Cod. 02-13
Revision:	08	19-02-2014	Cod. 01-14
Revision:	09	14-07-2014	Cod. 02-14

Our sales and technical offices are able to provide you with any additional clarification or information you may require, regarding the Bucket Crusher you purchased.

1 GENERAL INFORMATION

1.1 MANUFACTURER'S IDENTIFICATION DATA

The Bucket Crusher, model MB-C50 - BF 60.1 - BF 70.2 - BF 90.3 S2 - BF 90.3 S2 HD - BF 120.4 S2 - BF 120.4 S2 HD , is manufactured exclusively by:

Manufacturer: **MB S.p.A.**

Address: Via Astico, 30/A- 36030 FARA VICENTINO (VI) - Italy.

Telephone: +39 0445/308148

Telefax: +39 0445/308179

e-mail: info@mbcrusher.com

1.2 TECHNICAL SUPPORT

For any necessity regarding use, maintenance or request of spare parts, the Customer is asked to contact directly the nearest authorized workshop, specifying the machine's identification data listed on the plate here below.

We recommend not to carry out any repair or intervention, that is not indicated in this manual. All operations that require parts to be disassembled must be carried out only by people authorized by **MB S.p.A.** Only the technical staff of the company MB S.p.A. (mbservice@mbcrusher.com) or technical people trained by them, has the necessary knowledge about the machine and the special equipment, as well as the experience, to carry out any intervention correctly and cost-efficiently.





ATTENTION!

Any non-authorized intervention causes the warranty to lapse immediately.

Therefore, it must be specified that it is extremely important that the people operating with the machine read and assimilate this information very carefully.

1.3 MACHINE IDENTIFICATION AND CE MARKING

The machine identification data and the CE trademarks are located on a plate that is fastened by metal rivets to the load bearing structure.

		MB S.p.A. Via Astico 30/A, 36030 Fara Vicentino (VI) Italy Tel. 0445 308148 Fax. 0445 308179					
<small>COMPANY WITH QUALITY MANAGEMENT SYSTEM CERTIFIED BY DNV = ISO 9001:2008 =</small>		N° EP 1 532 321					
MODEL		<input type="text"/>					
SERIAL NUMBER N°		<input type="text"/>					
CONSTRUCTION YEAR		<input type="text"/>					
HYDRAULIC SYSTEM MAX PRESSURE		<input type="text"/>					Bar
WEIGHT		<input type="text"/>					Kg



CE DECLARATION OF CONFORMITY

(Annex II, Point A)

The company: MECCANICA BREGANZESE S.p.A.

Via Astico, 30/A
36030 - Fara Vicentino (VI)
Tel. 0445-300972

Represented by Sig. Guido Azzolin, born in Thiene on 23/05/1970, in his capacity as acting Chief Executive Officer / Managing Director.

The person authorised to draw up the technical brief is Sig. Azzolin Diego, in his capacity as owner of MB S.p.A., at the production facility in Via Astico 30, 36030 Fara Vicentino, Italy.

DECLARES

under its own liability that the interchangeable equipment

ECO - CRUSHER

FUNCTION: crushing and reduction of inert demolition material

MODEL:

SERIAL N°:

complies with the Machinery Directive 2006/42/EC and the PED Directive 97/23/EC (art. 3 para 3). It also declares that

- the following technical standards have been applied:

- **EN 12100:2010**

Fara Vicentino,

GUIDO AZZOLIN
(CEO/Managing Director)



Because of the continuous improvement of the products, MB reserves the right to make changes at any time without notice, for technical or commercial reasons.



www.mbcruiser.com

Copyright 2014 © MB S.p.A. - ALL RIGHTS RESERVED

1.4 NORMATIVE REFERENCES

The machine has been built in compliance with the provision of the Community Directives and Project Rules, pertinent and applicable from the moment of its insertion on the market.

List of the applied Community Directives:

- Directive 2006/42/EC and, within Italian borders, D.Lgs 27 Jan 2010 - Nr. 17

List of some of the applied Project Rules:

- UNI EN ISO 12100:2010

1.5 WARRANTY

MB S.p.A. provides customers with an 12-month Warranty period commencing on the date of shipment, as indicated on the transport documents

MB S.p.A. guarantees this product to be free from defective workmanship and/or materials. If a component is found to be defective, either as regards workmanship or materials, a replacement component will be supplied by any authorised MB S.p.A. workshop without charge. All faults covered by the warranty must be promptly reported to the MB SERVICE by e-mail mbservice@mbrusher.com, fax 00390445/850335 or phone 00390445/850425 as soon as they are identified.

NATURALLY

The Bucket must not be subject to improper use, must not be modified and must be correctly serviced:

- In particular, it is forbidden to crush flammable material, explosive material or material that can generate flammable, explosive, toxic or harmful powders.
- It is forbidden to use the Bucket Crusher in potentially explosive atmospheres.
- It is forbidden to crush material and rock using the outside of the bucket like a hammer.
- It is forbidden to work with the Bucket immersed in liquid.
- It is forbidden to handle material using the outside of the Bucket, apart from the front blade.
- It is forbidden to use the Bucket to dig in muddy soil or perform any operations on material other than crushing.
- It is forbidden to use the arm of the Bucket as a lever to move the excavator sideways.
- It is forbidden to use the Bucket on excavators with hydraulic systems that do not satisfy the flow and pressure requirements indicated by MB S.p.A. (see chapter 3).
- It is forbidden to crush material at temperatures higher than 100°C or lower than -20°C.
- When working, never operate with the excavator engine idling. Always rev the engine so that the hydraulic fluid can circulate at suitable pressures.
- The Bucket Crusher is used to crush and reduce the volume of inert demolition material. Pieces of hard material, such as granite or porphyry, can be crushed provided they are at least 50% smaller than the size of the crusher mouth as otherwise the jaws and all consumable components will be subject to considerably greater wear; to lengthen the lifetime of the jaws, do not crush damp materials. When crushing pieces of semi-hard material, they must be at least 30% smaller than the size of the crusher mouth. If the above instructions are not observed, serious problems will occur to the sliding wedges and to the entire area surrounding the jaws. If these materials are continuously crushed, the overall structure of the bucket will also be subject to considerable fatigue.
In these cases, MB S.p.A. declines all liability.

The manufacturer reserves the right to make changes, adaptations and improvements without having an obligation to the user or the owner.

Scheduled maintenance work must have been performed on the Bucket as indicated in the table of chapter 6 in this manual.

Scheduled maintenance work must have been performed on the Bucket components subject to wear as indicated in the table of chapter 6 in this manual.

- Components subject to wear and marked with the letter (C) in the attached “periodic replacement of components” diagram, are replaced at the user’s expense as the fact that they are worn does not mean the product is defective.

For all repairs and replacements covered by the warranty, the following conditions apply:

- All transport costs to and from the authorised MB S.p.A. workshop shall be charged to the customer.
- All labour costs for making the repairs shall be charged to MB S.p.A..
- All mission expenses relative to requests for technical work made to the parent company shall be charged to the customer.
- MB S.p.A. reserves the right to replace a component found to be faulty with an identical spare, following prior analysis by the manufacturer.
- Any accidental damage to the Bucket must be repaired using original MB spare parts. The use of unoriginal components prejudices/invalidates the warranty.
- The warranty does not cover damage to the Bucket caused by transport and/or handling.
- The warranty does not cover damage to the Bucket caused by errors made by the machine operator.
- The warranty does not cover damage to the Bucket caused by the incorrect setting of the hydraulic system of the operating machine connected to the Bucket.
- The warranty does not cover damage to the Bucket caused by the malfunction of the operating machine connected to the Bucket.
- For any points not covered above, consult the “USE AND MAINTENANCE“ manual supplied with the Bucket.

This manual was written in compliance with the instructions contained in:

- Directive 2006/42/EC and, within Italian borders, D.Lgs 27 Jan 2010 - Nr. 17
- UNI EN ISO 12100:2010

1.6 STRUCTURE OF THE MANUAL

1.6.1 PURPOSE OF THE MANUAL

The purpose of this manual is to provide the customer with all the information necessary not only to use the machine properly, but also to be able to manage it in the safest and most autonomous way possible.

1.6.2 IMPORTANCE OF THE MANUAL

The manual contains important safety information; it describes methods for carrying out particular operations that, if not carried out, could cause damages to people, property and equipments.

You could also find other useful information, that will improve your knowledge about the machine, as well as how to install and service it.

The Manual:

- is an integral part of the machine supply;
- is an essential instrument for machine use, running and maintenance;
- must be kept in good conditions for the entire life of the machine, and may be eliminated only after the machine has been scrapped;
- must be updated every time that manual update documentation is provided;
- must be provided to the machine purchaser, if it is sold to another user;
- reflects the technical status at the moment that the machine is sold.

1.6.3 CONTENT OF THE MANUAL

This manual provides all the necessary information to install and service the Bucket Crusher machine. We request you to follow the instructions, in order to obtain optimal performances and a correct machine functioning.

Instructions contained in the manual:

- general information;
- safety regarding the machine use;
- machine description;
- machine transport;
- machine functioning;
- machine maintenance;
- machine demolition.

This manual was written in compliance with the instructions contained in:

- Directive 2006/42/EC and, within Italian borders, D.Lgs 27 Jan 2010 - Nr. 17
- UNI EN ISO 12100:2010

1.6.4 ADDRESSEES

This manual is directed towards:

- the transport workers;
- workers employed in the installation, for connecting the machine to the auxiliary services (hydraulic);
- the responsible for functional test and personnel training;
- the machine operator;
- maintenance people;
- the responsible for final demolition;
- operators in charge of personnel security.

This manual must be kept by the assigned person in a suitable location, so that it is always available for consultation, and maintained in good conditions.

In case of loss or deterioration, the replacing documentation must be required directly to:

MB S.p.A.
Via Astico 30
36030 - FARA VICENTINO (VI) - ITALY

WARNING !



It is mandatory that this manual is read before starting with any operation.
The guarantee of the machine's correct functioning depends on the right application of all the instructions contained in this manual.

1.6.5 RESPONSIBILITY OF THE USER

The instructions provided in this manual do not replace, but integrate the obligations within the current legislation, concerning safety and accident prevention regulations.

With reference to what stated in this manual, **MB S.p.A.** declines all liability in case of:

- adversed use from national safety or accident prevention laws;
- incorrect preparation of the structures where the machine will be placed;
- failed or incorrect observation of the instructions provided in the manual;
- unauthorized changes on the machine;
- exceptional events.

The manual reflects the machine construction at the moment it is placed on the market. It is an integral part of it, and it complies with all laws, directives and standards that were effective at that time; it cannot be considered inadequate only due to successive updates based on new laws or new experiences. Any manual supplements, that the manufacturer considers appropriate to send to the users, must be kept together with the manual, as integral parts of it.

1.6.6 CONSERVATION OF THE MANUAL

It is obligatory to keep this manual and all its attached publications in an easily and accessible location near the machine, known to all users (operators responsible for running the machine and personnel responsible for servicing it).

Therefore:

- operators and maintenance people must be able to find it quickly at any moment;
- in case of loss or distruction, both for the manual and its attached publications, the customer may request a copy to **MB S.p.A.**;
- it must be kept, and follow the machine until its final demolition.

1.6.7 SYMBOLS AND DEFINITIONS USED IN THE MANUAL

The following symbols are used in the manual to point out particularly important information:



ATTENTION - DANGER

Signal of elevated danger: it indicates the extreme importance of the instructions to which it refers, and it is reported where there are dangers for the safety and health of the exposed people.



INFORMATION AND PRECAUTIONS

Useful instructions and recommendations: general useful information and instructions, to be observed and not disregarded, for all operators working with the machine.



OPERATING INSTRUCTIONS

Indicating a particular operating sequence.

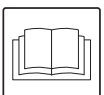

INSTRUCTION MANUAL

Read carefully the information contained in the instruction manual.

2 SAFETY REGARDING THE MACHINE

2.1 GENERAL SAFETY WARNINGS

In order to guarantee maximum operating reliability and safety, **MB S.p.A.** has carefully selected the material and the components to use in the construction of its machines, inspecting them regularly prior to delivery.

A good performance in the course of time depends also on a correct use and suitable maintenance, according to the instructions contained in this manual.

Trained people must regularly perform the required maintenance, inspection and overhaul operations in order to prevent breakdowns or accidents.

Operating anomalies are due, in most cases, to an incorrect maintenance.



In case of doubt regarding the functioning, stop the machine immediately!

- The machine has been built according to the current technical level and the known technical safety rules in force.

The operator's failure to observe the safety instructions, or his imprudence in using the machine, could cause serious accidents to the operator himself or to other people, animals, or could also cause machine breakages or damage other properties.

For this reason, it must be kept in mind that the machine's safety devices guarantee protection against accidents only if used correctly, and according to the safety instructions described in this manual.

BEFORE USING THE MACHINE, IT IS OBLIGATORY TO READ CAREFULLY THE SAFETY, USE, MAINTENANCE AND INTERVENTION INSTRUCTIONS, TO PROTECT ONE'S OWN AND OTHER PEOPLE'S SAFETY.

DANGER!

Be very careful and use maximum care when using the machine, as imprudence is the most frequent cause of accidents. The machine must be used by a competent adult.



ATTENTION!

Before connecting the Bucket Crusher to the excavator, make sure that it is suitable to support all its foreseen characteristics and functions.



2.1.1 ESSENTIAL CHARACTERISTICS OF THE MACHINE TOOL

Before you connect the crusher bucket to the operating machine and start it up, it is recommended to make sure that the basic requirements described here below are present in order to operate safely, safeguarding people's health.

- The final user has to make sure that the total weight of the load (weight of the bucket + weight of loaded material + coupling + any optional accessories) does not exceed the arm lifting capacity of the operating machine indicated in its manual; this check must be carried out for all positions with which you can operate.
- Remember to take into account the actual conditions of the operating machine, for example: arm type, carriage, counterweights, etc.
- The final user has to verify that the overturning capacity of the operating machine is suited for using the crusher bucket; this check must be carried out for all positions with which you can operate.
- To verify if your operating machines satisfies the minimum requirements, it is very important to contact the manufacturer/distributor.
- Driving the operating machine for the purpose of starting the equipment must be carried out exclusively by a competent and skilled adult, duly trained in driving site equipment.
- The activation command of the bucket must be the ON/OFF type, this can be a switch or a pedal. To start the bucket, it is mandatory to keep the command pushed, to stop the bucket it is enough to release the command.
- The machine must be equipped with an emergency stop command capable of stopping all crusher

bucket movements as quickly as possible.

- Make sure the operator has fully understood the meaning of all commands and their operation.
- The operator has to be familiar with and apply the safety conditions for using the machine in the workplace, in compliance with the laws in force in the user's country.
- In reference to: right side, left side, front part and rear part, this refers to the view from the driver's seat of the excavator.
- The operator has to be familiar with and properly interpret all indications contained in the instructions manual and the signs affixed to the machine: this will help prevent damage to people, property and the operating machine.
- Absolutely comply with the instructions contained in the Operating & Maintenance Manual and with general EC accident-prevention standards, as well as with the standards in force in the user's country.
- Always use the personal protection equipment required by directives EEC 89/686 and EEC 89/656; moreover, always do as instructed in the manual and according to the laws of the country where the machine is operating.
- Carefully read all the information printed on the adhesive labels concerning safety affixed to the machine.
- The operator has to avoid using the Crusher Bucket under unsuitable conditions or when under the influence of alcohol or drugs.
- It is important to organize the worksite so as to carry out the lowest number of operations, consistent with the job to be carried out.
- In order to safeguard the workers' health and safety, it is advisable to set up the worksite so as to be able to position the excavator (with the bucket as illustrated in the figure below) at a higher level compared to the material to be crushed; by doing so, the load radius is reduced and you avoid reaching the maximum working radius configuration.
- For use on excavators, it is recommended to refrain from carrying out the bucket loading phase with the carriage at a 90° angle (see figure below on the right); this allows results in less stability compared to the carriage being positioned straight (see figure below on the left).

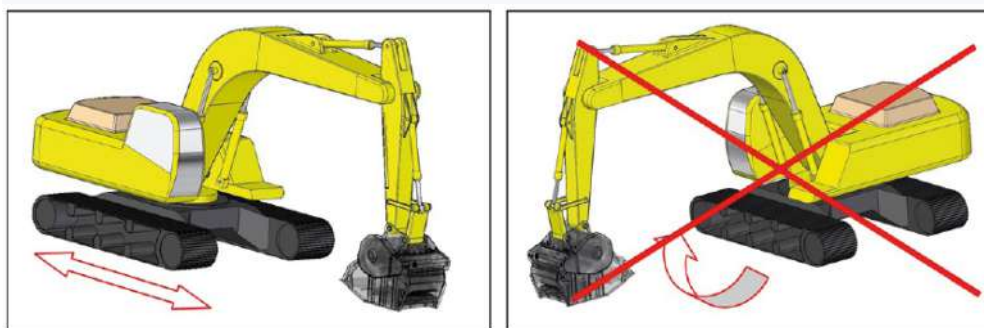

- For installation on wheeled excavators, it is mandatory to secure the stabilizers or the blade (if equipped) to the ground before you hook up and lift the equipment.
- For installation on operating machines other than wheeled or tracked excavators, please keep in mind all the indications provided here above and below for proper operation and to safeguard workers' health and safety.

ATTENTION!

Before setting the machine tool, make sure that no one is near it or in its working range.



- Keep children, people and animals away from the machine tool while using the Bucket Crusher.
- **It is forbidden to use the machine** to transport people, animals or property.
- **It is forbidden to climb** the machine structure.
- **It is forbidden** to use the machine as a lifting device.
- **It is absolutely forbidden** to come nearer to the machine while it is functioning.



DANGER !

If the machine jams, before carrying out any operation, turn the machine tool off and secure it (excavator, etc...).



ATTENTION!

The machine must not be used in case of anomalies. All liabilities are declined in case of injuries to people and/or properties, if the operator uses the machine with anomalies.



VERY IMPORTANT

REQUISITES OF EXCAVATOR

The weight of the work vehicle upon which the Bucket Crusher is installed, in order to maintain good stability and therefore manoeuvrability, is the following:

MODEL	MB-C50	BF60.1	BF70.2	BF90.3 S2	BF120.4 S2
EXCAVATOR WEIGHT	4-8 tons	≥ 8 tons	≥ 14 tons	≥ 20 tons	≥ 28 tons

2.2 FORSEEN USE

The crusher bucket (commercially known as Eco-Crusher) is an interchangeable piece of equipment that changes the function of a machine; it is sold to be assembled on a set of different machines (excavators or similar equipment), as long as they meet the minimum requirements in terms of weight and characteristics of the hydraulic system. It is designed to crush inert materials and/or demolition residue; the minimum specific requirements are detailed in chap. 3. It is intended exclusively for professional use, as there are no other foreseen or foreseeable situations that may vaguely suggest the use of the machine for non-professional applications; since this is a piece of equipment which, in terms of intended use and construction, can only function when coupled to an operating machine, it is expected that the machine be used only by professionally competent and specifically authorized operators.

In order to operate, the crusher bucket does not require the presence and/or the assistance of other people in addition to the operator of the main operating machine, so it is not expected for other people to be exposed to risks and/or dangers. As regards maintenance, it must be carried out as described in the Operating & Maintenance Manual, and only by skilled personnel. The specific requirements are listed on chap.6.

In case it is necessary for other people to be working or standing in proximity of the equipment while it is operating, defining the dangerous zone as the zone in which there may be dust generated by the processing activities, other people's exposure to risks and/or dangers can be limited through the use of PPE (face masks, specific filters, helmets, etc.) and according to the laws of the country where the machine is operating.

The Crusher Bucket is used for the crushing and volumetric reduction of inert materials coming from demolitions. With regards to this, it should be noted that the crushing of hard materials such as granite or porphyry is allowed, as long as the size of the material to be crushed is 50% smaller than the opening of crusher bucket; nevertheless, please be aware of the fact that the jaws and all the other consumable components will wear out much more quickly; moreover, in order to ensure long life to the jaws, it is recommended to avoid crushing damp materials. For the demolition of semi-hard materials, their size must be 30% less than the opening of the crusher bucket. In case the indications provided above are not complied with, significant problems will occur with the locking wedges and on the entire part adjacent to the jaws. Also, if said materials are crushed in a continuous manner, the overall frame of the crusher bucket will be subjected to considerable fatigue.

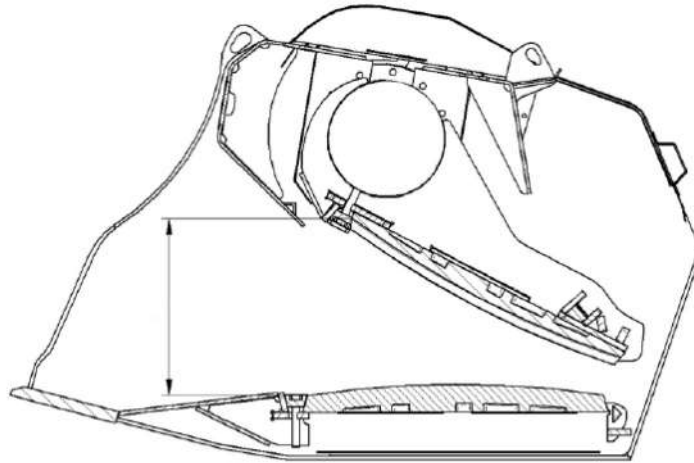

2.3 UNFORESEEN USE

The crusher bucket is not prepared for other purposes not listed in paragraph 2.2. Uses and/or jobs other than the ones for which the equipment was built are not foreseen: either as instinctive reactions in connection with possible malfunctions/breakdowns/accidents or other operating anomalies (no anomaly can generate abnormal situations that cannot be dealt with by simply cutting off power to the machine); or as a consequence of any negligence in using the machine by an incompetent or inadequate person (the equipment depends on a main operating machine whose use must be considered subject to authorization due to the use, for example, of an ignition key).

Furthermore, the equipment is NOT intended for the following uses:

- Direct extraction or excavation
- As something to lean the operating machine against
- With temperatures above 100°C or below -20°C
- To transport people, animals or objects
- In the presence of flammable or explosive materials or materials that may generate flammable, explosive, toxic or harmful dust.
- For lifting operations

The following is also forbidden:

- Approaching the crusher bucket while it is working
- Climbing onto the frame of the equipment
- Carrying out any type of job on the crusher bucket while it is working
- Carrying out any type of operation that may jeopardize the operator's safety or the safety of people or property located nearby.
- Using the Crusher Bucket in potentially explosive atmospheres.
- Crush materials and various rocks with the outer part of the case, in other words as a hammer.
- Operating with the Bucket submerged in liquids.

- Using the Bucket to move material using the external parts of the case other than the front cutter.
- Using the Bucket as leverage through the arm for the lateral movements of the excavator.
- During the crushing phase, it is highly advisable to refrain from operating the equipment with the excavator running at minimum speed; always keep the engine accelerated to allow the hydraulic deliveries to work with adequate pressure values.









ATTENTION !

MB S.p.A. does not take on any liability in case of damages to people and/or properties, due to unforeseen uses of the Bucket Crusher, by the customer or a third part.

2.4 USE OF PERSONAL PROTECTIVE EQUIPMENT (PPE)

Before the operator, designated by the employer (customer) to use this machine, begins with starting, using, servicing or making other interventions on it, he must wear all the personal protective equipment(PPE), necessary to guarantee his protection, according to what is foreseen by the general accident prevention laws in force in the Country in which the machine is used.

The personal protective equipment that the operator must use is listed below:

	Use protective garments
	Use protective footwear
	Use protective gloves
	Use protective glasses
	Use protective headsets
	Use protective helmet



ATTENTION !

MB S.p.A. declines all liability for any accidents that may occur to the operator, due to the lack of use of the personal protective equipment.

2.5 ADHESIVE SAFETY LABELS

Adhesive safety labels are applied to the Bucket Crusher.

All the adhesive safety labels listed here below must be always in perfect conditions and well visible.

INFORMATION



Before using the machine, the operator must read the information in the instruction manual regarding the area pointed out by the label.

It is obligatory to replace the damaged labels, requesting them to MB S.p.A.







ATTENTION !

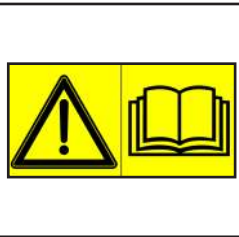

The operator must know and comply with the contents of the adhesive labels applied to the Bucket Crusher. Failed observation could in fact cause serious accidents.

The adhesive labels applied on the Bucket Crusher are arranged as shown in the figures here below, using the progressive numbers indicated in the label key as a reference. For every label, a code is provided for reordering.

The safety labels are represented and explained in the following table:

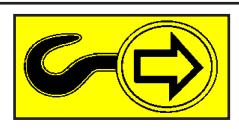
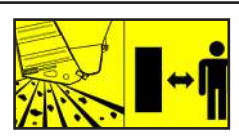
	<p>1. ATTENTION: It is forbidden to approach or stand near the Bucket Crusher. Crushing hazard. COD. 801000101</p>
	<p>2. ATTENTION: It is forbidden for the operator or other people to climb the Bucket Crusher. COD. 801000201</p>
	<p>3. ATTENTION: Before using the Bucket Crusher, read the manual in order to adequately understand the instructions and its functioning. The Bucket Crusher must be used only by a competent adult. Pay attention and take care when using the machine, as imprudence is the most frequent cause of accidents. COD. 801000301</p>
	<p>4. ATTENTION: It is forbidden to start and use the machine without the safety protections. COD. 801000401</p>
	<p>5. ATTENTION: Turn the machine's motor off and remove the keys from the panel before working on the Bucket Crusher. COD. 801000501</p>
	<p>6. ATTENTION - RESIDUAL RISK: It is forbidden to go near jaws while the machine is working and feeding hoses are connected. COD. 801006002</p>
	<p>7. ATTENTION: Lifting hook</p>
	<p>8. ATTENTION: It is forbidden to approach or stop near the Bucket Crusher. Danger of object expulsion. COD. 801001801</p>

REAR SIDE

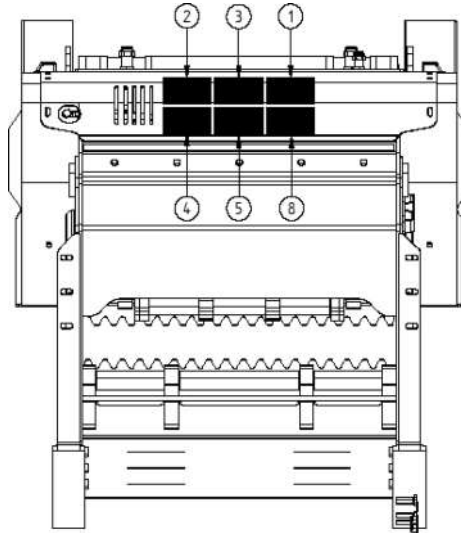

RIGHT SIDE

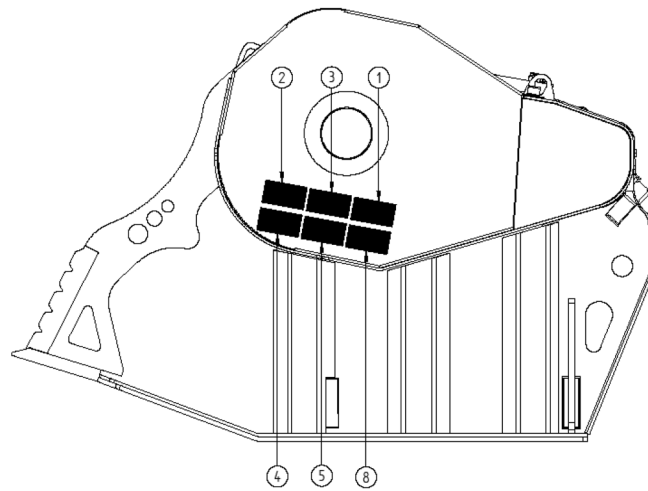

LEFT SIDE

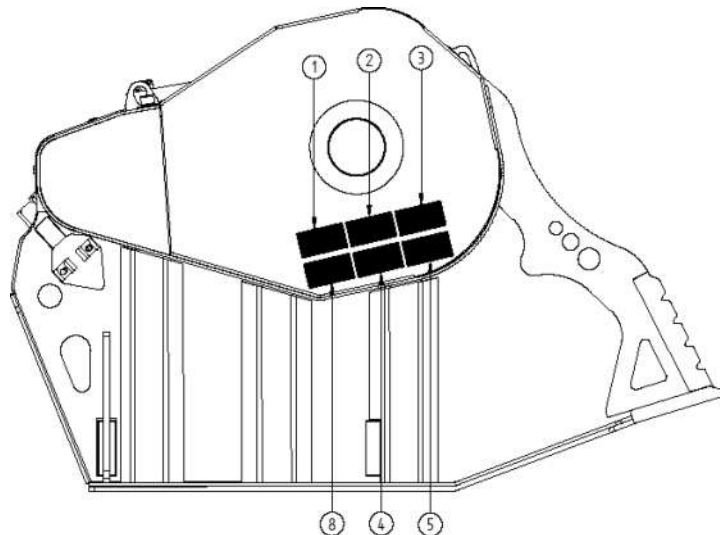

2.6 ADDITIONAL SAFETY DIRECTIVES

2.6.1 PROCEDURE FOR UNBLOCKING THE MATERIAL

If material gets jammed inside the bucket crusher and blocks it, position the bucket crusher vertically with the blade facing downwards and lightly strike the ground until the jammed material falls out of the mouth. The operator must never personally and/or manually remove any pieces of material jammed inside the bucket. MB declines all liability if the above is not observed.

If the Bucket Crusher jams, proceed as follows:

- Stop the jaw movement;
- Position the Bucket Crusher so that the loading entrance faces downward;
- Unload the material contained in the Bucket Crusher;
- Move the jaw slowly;
- If necessary, shake the Bucket Crusher slightly, to its stop position.

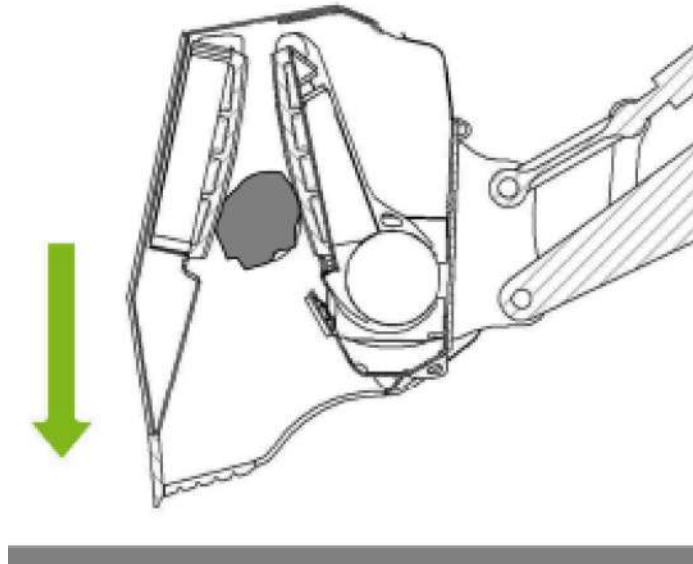

ATTENTION !

If the machine jams, it is severely forbidden to bang the Bucket Crusher horizontally on the ground or against the objects. In case of damages caused by this operation, the manufacturer refuses all liability.

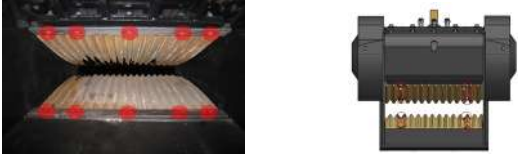

2.6.2 RESIDUAL RISKS

<p>Residual risks</p> <p>In case there are some residual risk, even if all protection's measures have been taken and attached to the project of the machine, the operator must take all others protection measures.</p>	<p>The residual risk interests jaws, the working part of the machine. It's not possible to enclose them or to protect them with further devices that deny the risk to be kept in touch with jaws.</p>  <p>Please consider that a part from the operator who uses the excavator, nobody else is supposed to be in the crushing area of the machine. All residual risks are marked in the Use and Maintenance manual supplied together with the machine.</p>
<p>Risk estimation</p> <p>Damage entity: High Probability: Remote</p>	<p>Risk evaluation:</p> <p>Negligible risk</p>
<p>In order to avoid damages to persons or things, connected to the residual risk, it is important the machine is used by trained personel, who will have to read this Use and Maintenance Manual, paying attention to all safety labels (p. 2.5). The user, in case of maintenance on the machine, has to make sure the machine is not working and feeding pipes are not connected.</p>	

2.6.3 STANDARD EQUIPMENT - KIT BOLTS

Following Directive 2006/42/CE, all the protection case needs min 2 bolts for the fixing, despite the fact that also with only one bolt there is no risk that this moves from its place. (the bolt has to be correctly fixed with the right key furnished together with the equipment).

Every bucket has been equipped with a kit screw (see the table down), together with standard equipment, so the substitution of the screw is immediate in case of loss or damage . This facilitates the customer and the customer can work in high security. It is important to replace the damaged component immediately.



ATTENTION !

Before you proceed with the removing of protection case, it is necessary to check that the operating machine is off and the oil supply hoses are disconnected

Cod. KBDM2006		
Product Code	Description	Quantity
100103501	screw TE M10x35zn	10
100102501	screw TE M10x25zn	10
106103001	plate washer M10x30 sp.4 zn	20
108001001	washer DE M10 zn	20

If you need the spare parts, the bolts and screws of blocking case, MB S.p.A. is at your disposal. The bolts that are used for the clamping are commercial and you will also find them easily in your country.

2.6.4 STABILITY OF THE SYSTEM “WORKING MACHINE AND BUCKET CRUSHER”

Make sure the load capacity of the operating arm of the working machine is greater than the fully laden weight (own weight plus the weight of the loaded material) of the bucket crusher (to prevent the danger of tipping when the arm extends and rotates by 360°).

CORRECT POSITION OF THE WORKING MACHINE

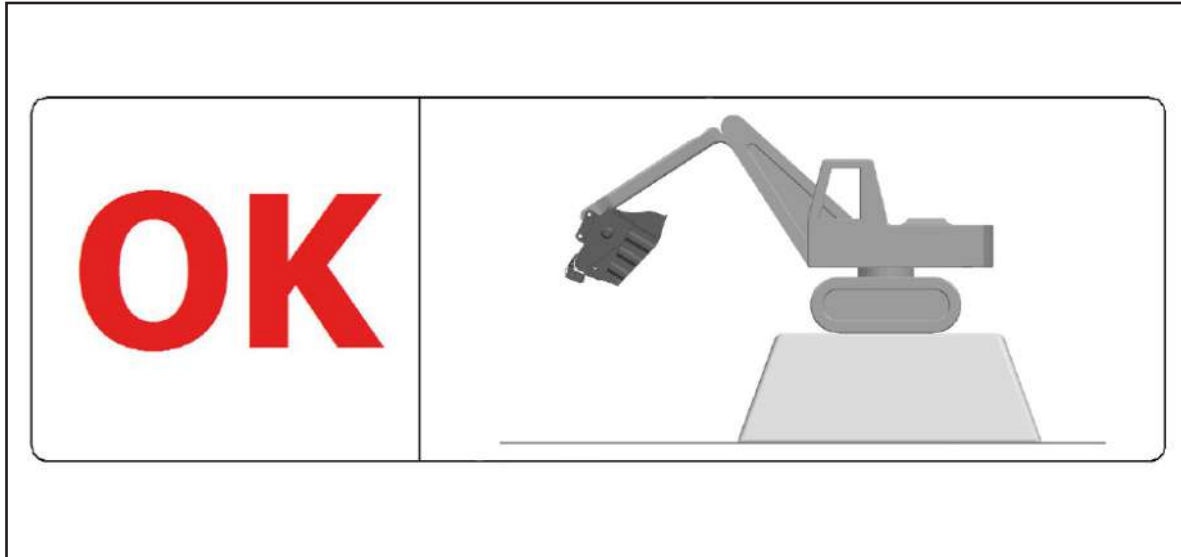

TIPPING HAZARD

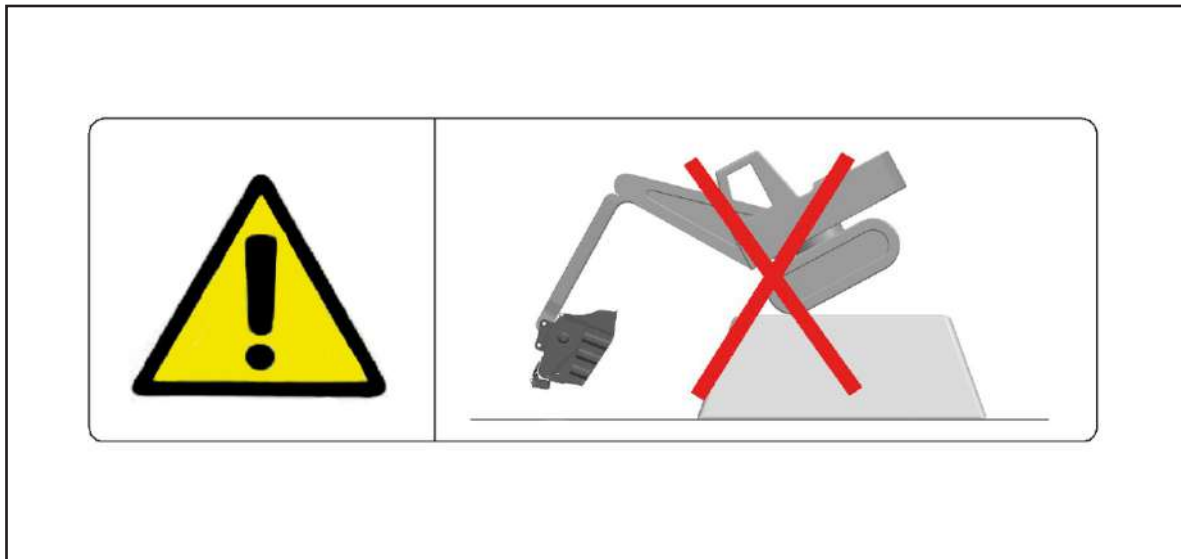

ATTENTION !

IF THE DIGGER'S ARM CAPACITY IS UNSATISFACTORY, THERE'S A REAL TIPPING HAZARD.

3 TECHNICAL DESCRIPTION OF THE BUCKET CRUSHER

3.1 TECHNICAL DATA CRUSHER BUCKETS

Description	U.M.	MB-C50	BF60.1	BF70.2	BF90.3 S2	BF 90.3 S2 HD	BF120.4 S2	BF120.4 S2 HD
Length +/- 3%	mm	1230	1790	2170	2150	2150	2150	2150
Width +/- 3%	mm	1000	1000	1100	1350	1350	1650	1650
Height (connector and palte not included) +/- 3%	mm	800	1160	1240	1450	1450	1450	1450
Max. capacity +/- 20%	mc	0,125	0,305	0,435	0,642	0,642	0,840	0,840
Unladen weight (connector and palte not included) +/- 5%	Ton	0,75	1,5	2,25	3,5	4,0	4,9	5,5
Min. oil flow	litres1'	90	120	150	180	180	205	205
Max. pressure in delivery system	bar	200	230	230	230	230	230	230
Max. pressure in return system of drainage +/- 10%	bar	20	20	20	20	20	20	20
Bucket aperture								
Width +/- 1%	mm	600	600	700	900	900	1200	1200
Height +/- 6%	mm	250	470	510	450	450	460	460
Jaw aperture								
Minimum +/- 20%	mm	15	20	20	20	20	20	20
Maximum +/- 10%	mm	70	100	120	120	120	120	120

3.1.1 OIL SPECIFICATIONS:

Viscosity at 100°C	mm ² /s 6,8
Viscosity at 40°C	mm ² /s 45
Viscosity index	100
Flashpoint OC	212°C
Pour point	-27°C
Volumetric mass at 15°C	0,880 Kg/l
Filter porosity	Max 3 micron

3.2 EXCAVATOR HYDRAULIC SYSTEM PARAMETERS

Description	U.M.	MACCHINA OPERATRICE				
		MB-C50	BF 60.1	BF 70.2	BF 90.3 S2 - HD	BF 120.4 S2- HD
Max oil flow rate	Liters/1'	140	280	280	280	280
Min oil flow rate	Liters/1'	90	120	150	180	205
Min oil pressure	Bar	200	230	230	230	230
Max return backpressure of drainage	Bar	20	20	20	20	20
Max. backpressure without drain	Bar	10	10	10	10	10

OPTIMAL EXCAVATOR'S HYDRAULIC SYSTEM REGULATION FOR A CORRECT FUNCTIONING OF THE BUCKET CRUSHER.

MB-C50

For an optimal use of MB-C50, it is recommended to calibrate the excavator with a min. of 90 lt. of oil and at min. 200 bar, and to check that the third pipe, of drainage, is connected directly to the excavator's tank, and without backpressure. **Without the drain line, the back pressure on the return line must never overcome the value of 10 bars.**
IMPORTANT: 90 lt. and 200 bar must be present at the same time in the system.

BF 60.1

For an optimal use of BF 60.1, it is recommended to calibrate the excavator with a min. of 120 lt. of oil and at min. 230 bar, and to check that the third pipe, of drainage, is connected directly to the excavator's tank, and without backpressure. **Without the drain line, the back pressure on the return line must never overcome the value of 10 bars.**
IMPORTANT: 120 lt. and 230 bar must be present at the same time in the system.

BF 70.2

For an optimal use of BF70.2, it is recommended to calibrate the excavator with a min. of 150 lt. of oil and at min. 230 bar, and to check that the third pipe, of drainage, is connected directly to the excavator's tank, and without backpressure. **Without the drain line, the back pressure on the return line must never overcome the value of 10 bars.**
IMPORTANT: 150 lt. and 230 bar must be present at the same time in the system.

**BF 90.3
S2
BF 90.3
S2 HD**

For an optimal use of BF90.3 S2 and BF90.3 S2 HD, it is recommended to calibrate the excavator with a min. of 180 lt. of oil and at min. 230 bar, and to check that the third pipe, of drainage, is connected directly to the excavator's tank, and without backpressure. **Without the drain line, the back pressure on the return line must never overcome the value of 10 bars.**
IMPORTANT: 180 lt. and 230 bar must be present at the same time in the system.

**BF120.4
S2
BF120.4
S2 HD**

For an optimal use of BF120.4 S2 and BF120.4 S2 HD, it is recommended to calibrate the excavator with a min. of 205 lt. of oil and at min. 230 bar, and to check that the third pipe, of drainage, is connected directly to the excavator's tank, and without backpressure. **Without the drain line, the back pressure on the return line must never overcome the value of 10 bars.**
IMPORTANT: 205 lt. and 230 bar must be present at the same time in the system.

3.3 EXCAVATOR'S HYDRAULIC REGULATION

The excavator must be adjusted as indicated by its manufacturing company; if these indications are not followed correctly, structural failures could occur.

Check that:

- The carrying capacity of the working arm is greater than or equal to the weight at full load (its own weight, plus the weight of the loaded material) of the Bucket Crusher (to prevent overturning while the arm is traveling, or rotating 360°);
- The control of the oil delivery to the Bucket Crusher must be of maintained operation type;
- The machine must be equipped with an emergency stop control, that can stop the movement of the Bucket Crusher in the shortest period of time possible.

3.4 INTERFACES

In order to function, the crusher bucket requires the operator to carry out special manoeuvres; the operator interface is located on the operating machine. The operation that regulates the sending of the equipment takes place by means of a special ON / OFF command with continuous action, such as a switch or a pedal directly; they are both located inside the control cab of the operating machine. As regards the handling operation of the crusher bucket, the operator has to use joysticks that, depending on the operating machine type and model, allow movement of the excavator arm, which is in turn connected to the bucket. Movement takes place by means of hydraulic pistons managed precisely by the joysticks positioned inside the cab.

Driving the operating machine for the purpose of starting the equipment must be carried out exclusively by a competent and skilled adult, duly trained in driving site equipment.

4 GENERAL DESCRIPTION

4.1 GENERAL DESCRIPTION

ATTENTION !

Make sure that the transport and handling areas cannot be accessed by unauthorized people.



The Bucket Crusher is prepared for the transport to the customer by MB S.p.A., which is responsible for the packaging and shipping phases.

In addition, the following is supplied together with the machine:

- Information kit (instruction manual, hydraulic circuit warning and CE certificate).

4.2 MACHINE TRANSPORT

The transport must be done by professionally qualified people.

The machine must be transported avoiding damages to the parts.

Before handling the machine, check that:

- All protections and guards are correctly closed and secured;
- With relation to the type of transport, the machine and its components should be protected from all possible impacts and stresses.

Normally, the machine is sent to the user by land, via truck.

When the machine arrives, the user must:

- Control the Bucket Crusher upon delivery, to check if there are possible damages (breakages or substantial dents) caused by the transport.
- In this case, it must be reported immediately to the transport company, and the clause **“Accepted with reservation”** must be written on the delivery note.

If there are damages, contest them to the transport company, via a written report within eight days from the machine receiving.

If damages caused during transport are noticed upon delivery, this must be reported promptly to **MB S.p.A.**

It is also necessary to check that the material that has arrived corresponds to what listed in the detailed shipping list. Also in this case, any irregularities must be reported promptly to **MB S.p.A.**

4.2.1 MACHINE TRANSPORT: FASTENING

Each time the Bucket Crusher must be transported, it must be anchored to the truck's loading floor using cables that pass through the specific anchoring points, as shown in the following photos.



4.2.2 UNLOADING OF THE BUCKET CRUSHER



ATTENTION !

Upon arrival to the customer site, the machine must be handled with maximum care and moved both outside and inside, with suitable means for its capacity, with regard to its own weight.



All parts of the machines, where the lifting hook can be used are properly indicated by this sticker.

OPERATING INSTRUCTIONS

- The unloading, lifting and handling operations must be directed by a single responsible person, and be carried out by suitably instructed, qualified people. They must wear the proper accident prevention protections, and have suitable equipment, available before proceeding with the operations.
- Before starting with these operations, identify and check the entire machine handling area, including where the transport vehicle will be parked and the installation site, in order to identify any dangerous points.
- It is forbidden to climb up the machine, to stand and/or pass under it during handling.
- It is forbidden for all unauthorized people to access the transport and handling areas.
- All operators must keep a safety distance, in order not to be hit in case the machine or its parts fall to the ground.
- The vehicle used for lifting and transport must have a carrying capacity suitable for the weight to raise.
- Check that the lifting cables are certified and have the label reporting the manufacturer and carrying capacity data.
- Inspect the cables before using them: they must not be damaged, have broken wires or signs of wear.
- Do not twist or knot the cables. Follow the instructions indicated by the manufacturer.
- The same warnings must be applied to the use of chains.

LIFTING REGULATIONS FOR UNLOADING THE BUCKET CRUSHER

- Prepare the lifting system (travelling crane) with a length and a carrying capacity suitable for the weight to support.
- Proceed with the settlement, moving the lifting system with short movements, until optimal stability conditions are obtained.
- Lift slowly, hooking to the specific lifting hooks (see following photo), and move with maximum care, avoiding oscillations.

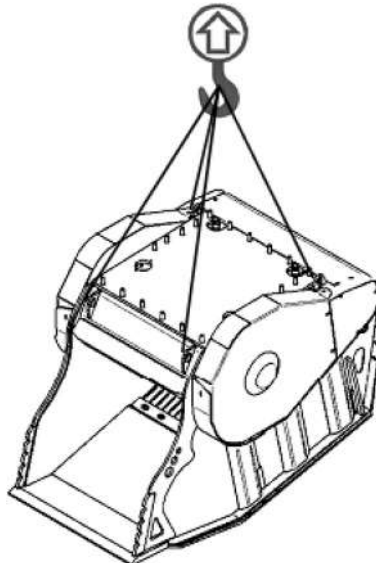

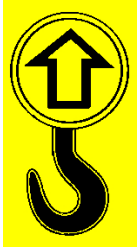
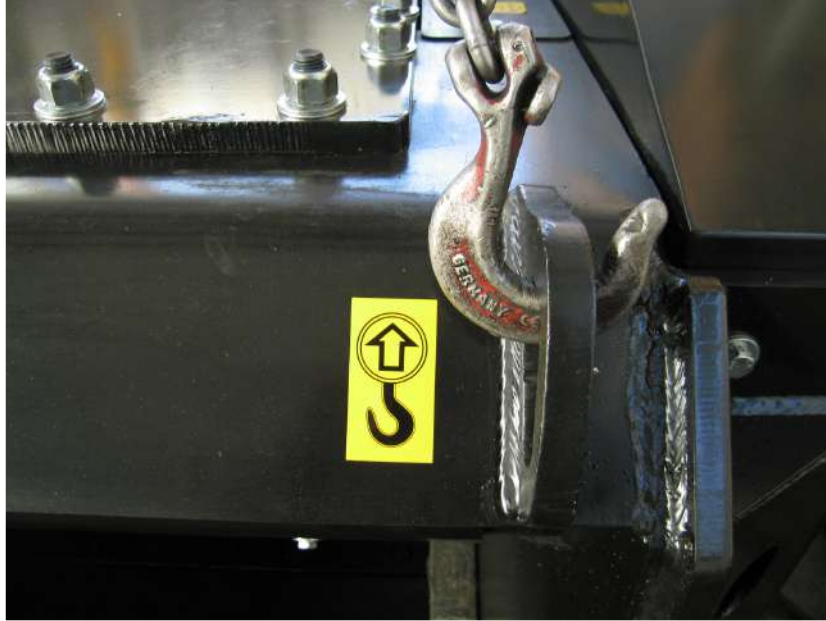

4.3 HYDRAULIC SYSTEM CONNECTION

You can operate the Bucket Crusher using the hydraulic circuit, installed on the machine tool on which it is applied.

Figure 4-01 shows the connection points for the hydraulic hoses.

Reference 1 shows the connection for the flexible \varnothing 1" feed hose, with suitable characteristics for supporting an operating pressure of 250 bar.

Reference 2 shows the connection for the flexible \varnothing 1" return hose, with suitable characteristics for supporting a pressure of 50 bar.

The connectors on all Bucket Crusher models (except MB-C50) are 1" gas (BSPP) both on the delivery line as well as on the return line.

The connectors on MB-C 50 are 3/4" gas (BSPP) both on the delivery line as well as on the return line, connector for the drain line is 1/2" gas (BSPP).

On all other models the drain connector is 3/4" gas (BSPP).

For excavators with opposite delivery, it is possible to reverse the flexible hoses on connectors 3 and 4; then, remove the hose on the sub-casing connector no. 3 (see figure 4-02) and position it on the sub-casing connector no. 4 (see figure 4-02).

Do the opposite procedure for hose no. 4.

ATTENTION !

Check that the hydraulic hoses used for the connection correspond to the specifications required by the standard EN 982.

ATTENTION !

During any reversal of the flexible hoses on connectors 3 and 4, make sure that the system is free of oil; otherwise, collect any leaks using specific vessels.

ATTENTION !

Do not invert IN and OUT bucket hoses with IN and OUT of operating machine hoses



FIG. 4-01

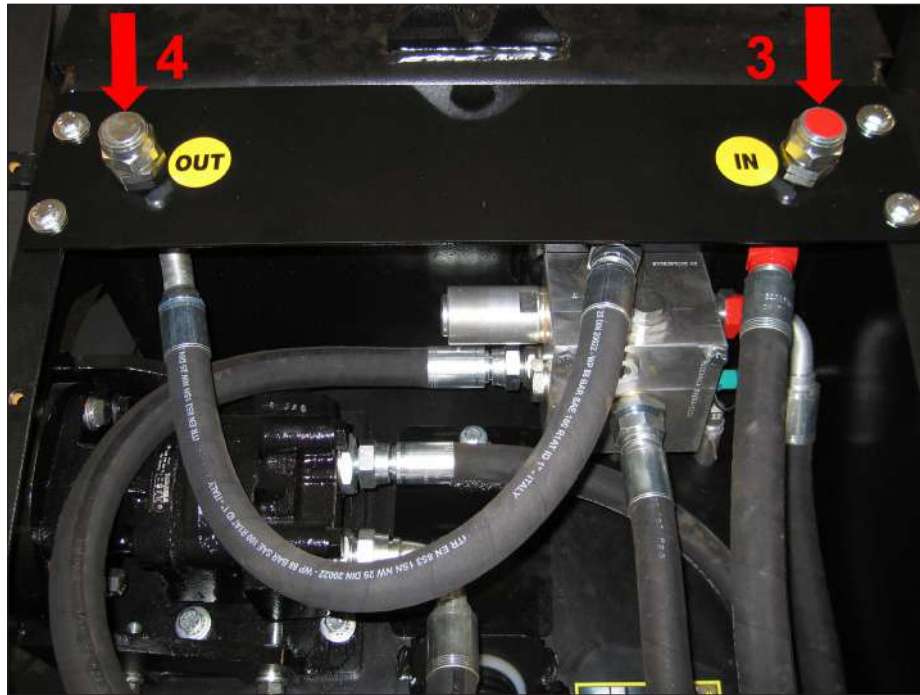

FIG. 4-02

5 MACHINE FUNCTIONING

5.1 MACHINE START-UP



ATTENTION !

Before connecting the Bucket Crusher to the machine tool, make sure that it is suitable for all the foreseen characteristics and uses (see the previous paragraphs 2.1 and 3.2).



ATTENTION !

Make sure that the machine tool, that operates the Bucket Crusher, has a hydraulic circuit with a minimum load, a delivery pressure and a return backpressure as indicated in table 3.1.

5.2 INSTALLATION

In this chapter, an outline for common operations during the installation phase is reported.



1) CHECK OF THE EXCAVATOR'S CALIBRATION

CHECK THAT THE EXCAVATOR IS CORRECTLY CALIBRATED, WITH THE REQUIRED PRESSURE AND FLOW (THE CALIBRATION OF THE EXCAVATOR MUST BE DONE BY THE CUSTOMER, AT HIS COST AND RESPONSIBILITY).



2) GENERAL CHECK OF THE BUCKET CRUSHER

CHECK THAT THE BUCKET CRUSHER IS EQUIPPED WITH ALL THE NECESSARY THINGS, ITS GENERAL SUPPLY, (ADJUSTMENT SHIMS, MAINTENANCE AND USE MANUAL, STANDARD EQUIPMENT).



3) CHECK OF THE CONNECTION OF THE FLEXIBLE HOSES

CONNECT THE FLEXIBLE HOSES FROM THE EXCAVATOR TO THE BUCKET CRUSHER. PAY ATTENTION TO THE FEED AND RETURN HOSE.



4) CHECK THE VALVE OPENING ON THE EXCAVATOR'S ARM

CHECK THAT THE VALVES ON THE EXCAVATOR'S ARM ARE OPEN.



5) CHECK OF THE PRESSURE ON THE RETURN LINE (GREEN PRESSURE TEST)

CHECK THE PRESSURE ON THE RETURN LINE – TEST THE PRESSURE ON THE GREEN VALVE ON THE HYDRAULIC PLANT.

6) CHECK OF THE PRESSURE ON THE FEED HOSE (IF POSSIBLE, BLOCKING THE BUCKET CRUSHER)

TO BE VALUED IN THE CASE THAT THE BUCKET CRUSHER DOES NOT WORK CORRECTLY.

7) CHECK OF THE SPRING

CHECK THE WORK AND THE CORRECT MOVEMENT OF THE SPRING.

8) MAINTENANCE AND PERIODICAL CHECKS

READ CH. 6 OF THE USE AND MAINTENANCE MANUAL.

5.2.1 CONNECTING THE MACHINE WITH A FIXED COUPLING



	<p>Insert the machine tool's arm between the two brackets on the Bucket Crusher, foreseen for the connection.</p>
	<p>Align the holes, on the end of the machine tool's arm, with the holes of the connection brackets.</p>
	<p>Do not misalign the pins.</p>
	<p>Insert the specific metal pins of the machine tool, normally provided, into the aligned holes.</p>
	<p>Lock the pins with the shear bolt, to prevent accidental unthreading.</p>
	<p>View of the complete fixed coupling.</p>

Then, connect the hydraulic hoses according to the instructions provided in paragraph 4.3

IMPORTANT

Operations of connection and disconnection have to be performed by the same machine operator.



5.2.2 CONNECTING THE MACHINE WITH A QUICK COUPLING

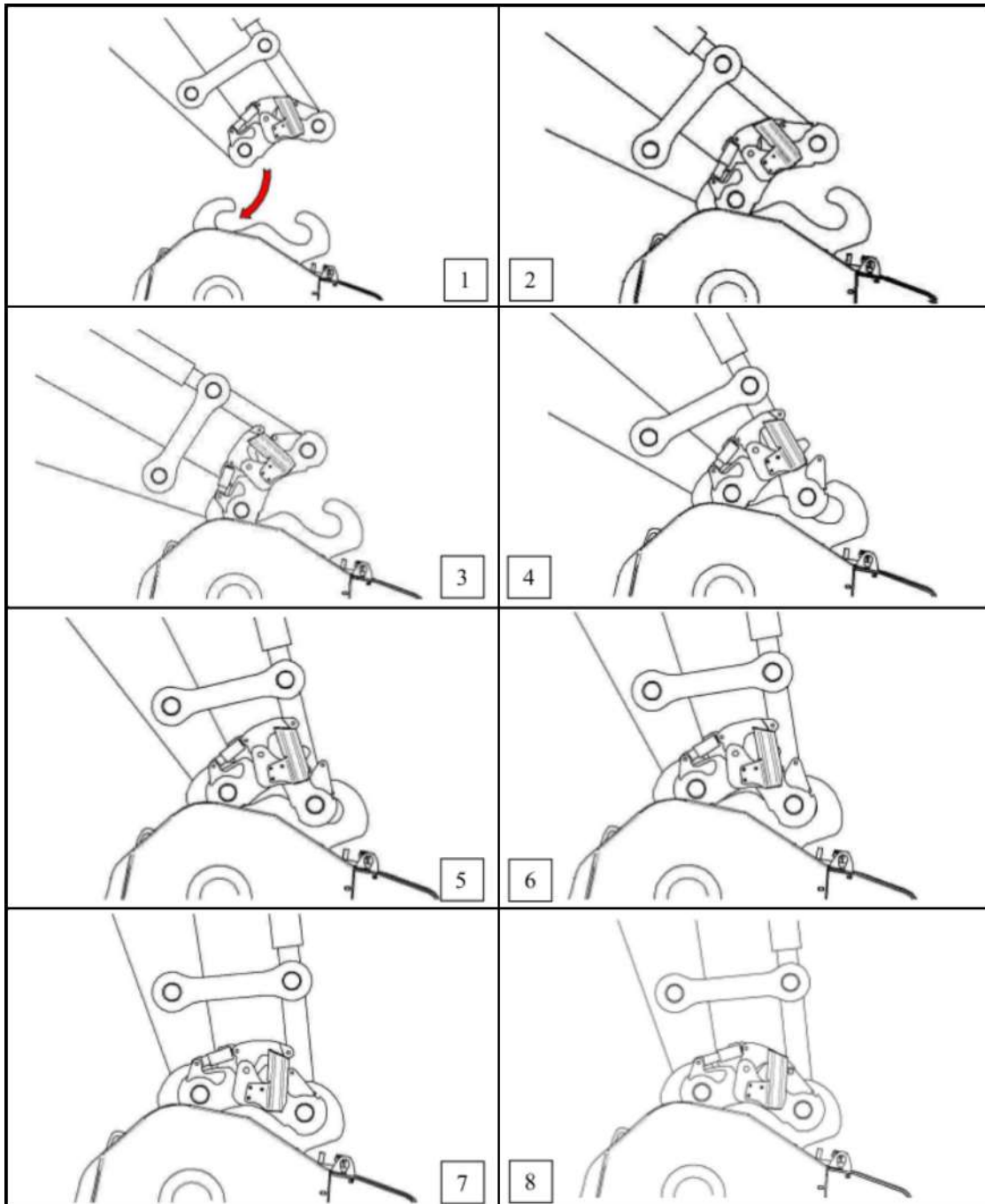

Descriptive sequences

1. Near the bucket.
2. Connect the coupling to the female brackets of the bucket.
3. Activate the rod of the arm.
- 4-5-6-7. Connect to the rear part of the female coupling using the rod.
8. Once the coupling is closed, fasten the screws.

Please refer to the quick coupler manufacturer operating instructions.

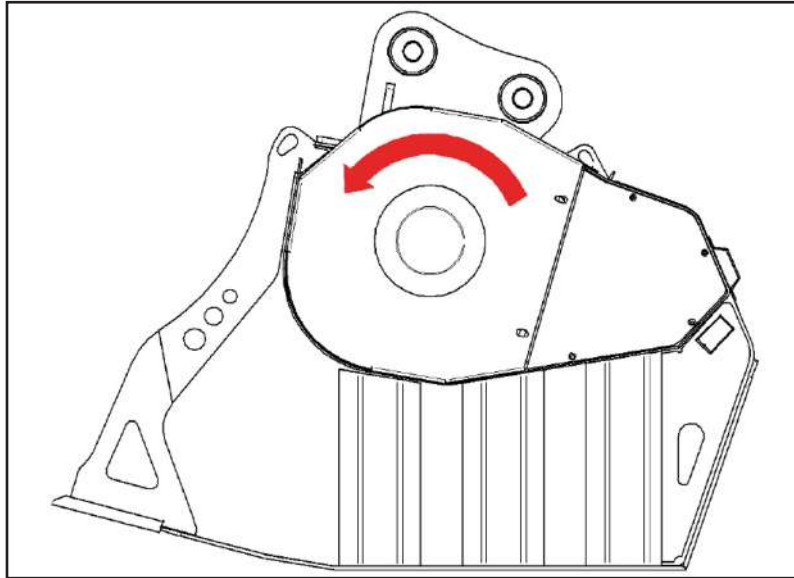

- Let the motor run for few minutes.
During winter, with low temperatures, leave it started up for approximately 10 minutes, so that the temperature of the hydraulic oil increases of around 40° before starting to work.
- At this point, stop the Bucket Crusher rotation, start with the filling phase, activate again the control in a slow and gradual manner, increasing the speed to the specified maximum of 300 rpms.
- Then, rotate the Bucket Crusher slowly, so that the outlet faces downward, helping the crushed product to exit.
- Once the product inside the Bucket Crusher has been crushed, repeat the loading operation.

5.3 NOISE EMITTED BY THE EQUIPMENT

The resounding power rating, produced by the equipment, has been evaluated by: SOVECO S.r.l. - Società veneta per l'ecologia – with the supervision of the Technical Manager. This assessment has been described in the report dated January 27, 2003, and has been signed by the same Technical Manager.

The measurements were taken with fully loaded machine, under normal weather conditions, without rain, with a microphone always equipped with a wind cover.

The calculation of the resounding power emitted from the source was calculated according to UNI EN ISO 3744.

The rating covered all the produced models, revealing substantially homogenous results.

Resounding power level emitted by fully loaded equipment:

LWA = 111.3 dB(A).

5.4 ADJUSTMENTS ON THE MACHINE

LIST OF THE ADJUSTMENT SHIMS SUPPLIED WITH THE EQUIPMENT

MODEL	MB-C50	BF60.1	BF70.2	BF90.3 S2	BF120.4 S2
Nr. OF SHIMS (SUPPLIED)	7	7	7	6	6
MAX. NR. OF SHIMS THAT CAN BE INSERTED	6	6	6	5	5
NR. OF SHIMS - AS A SPARE PART	1	1	1	1	1



ADJUSTMENTS ON MB-C50 MACHINE

Jaw opening adjustment

Before adjusting the jaw opening, the operator must remove the protective case, unscrewing the rear tightening screws.

	Remove the screw and the self-locking nut.
	Loosen the hose, using the specific wrench provided with the Bucket Crusher, in order to free the connecting - rod.
	At this point, to reduce the jaw opening, add adjustment shims, and to increase it, remove them.
	Once added the adjustment shims, retighten the hose so that the red part above the spring coincides with the red part of the indicator at the side. Position the hose so that the safety bolt enters in the corresponding hole on the threaded bar.
	Once the sizing adjustment operation is completed, check that the shims covering case is well fixed, so that they cannot escape during the crushing phase.

After adjustment, slowly turn the jaw and check that the spring has its min. and max. established range

(during working, the spring must never exceed its upper max. point, shown in red). Then, restore the protections and the protective case where the spring is located, using the fastening screws.

Flywheel regulation and fixing



ATTENTION !



Possible regulation and fixing operations of the flywheel must be done only by qualified people, authorized by the manufacturer.

ADJUSTMENTS ON BF 60.1 MACHINE

Jaw opening adjustment

Before adjusting the jaw opening, the operator must remove the protective case, unscrewing the rear tightening screw



	<p>Remove the screw and the self-locking nut.</p>
	<p>Loosen the hose, using the specific wrench provided with the Bucket Crusher, in order to free the connecting - rod.</p>
	<p>At this point, to reduce the jaw opening, add adjustment shims, and to increase it, remove them.</p>



Once added the adjustment shims, retighten the hose so that the red part above the spring coincides with the red part of the indicator at the side.

Position the hose so that the safety bolt enters in the corresponding hole on the threaded bar.



Once the sizing adjustment operation is completed, check that the shims covering case is well fixed, so that they cannot escape during the crushing phase.

After adjustment, slowly turn the jaw and check that the spring has its min. and max. established range (during working, the spring must never exceed its upper max. point, shown in red).

Then, restore the protections and the protective case where the spring is located, using the fastening screws.

Flywheel regulation and fixing

ATTENTION !

Possible regulation and fixing operations of the flywheel must be done only by qualified people, authorized by the manufacturer.





ADJUSTMENTS ON BF 70.2 MACHINE

Jaw opening adjustment

Before adjusting the jaw opening, the operator must remove the protective case, unscrewing the rear tightening screws.



Then, loosen the spring as described in the following procedure:

	<p>Remove the screw and the self-locking nut.</p>
	<p>Loosen the hose, using the specific wrench provided with the Bucket Crusher, in order to free the connecting - rod.</p>
	<p>At this point, to reduce the jaw opening, add adjustment shims, and to increase it, remove them.</p>
	<p>Once added the adjustment shims, retighten the hose so that the red part above the spring coincides with the red part of the indicator at the side. Position the hose so that the safety bolt enters in the corresponding hole on the threaded bar.</p>



Once the sizing adjustment operation is completed, check that the shims covering case is well fixed, so that they cannot escape during the crushing phase.

After adjustment, slowly turn the jaw and check that the spring has its min. and max. established range (during working, the spring must never exceed its upper max. point, shown in red). Then, restore the protections and the protective case where the spring is located, using the fastening screws.

Flywheel regulation and fixing



ATTENTION !

Possible regulation and fixing operations of the flywheel must be done only by qualified people, authorized by the manufacturer.



ADJUSTMENTS ON BF 90.3 S2 AND BF 90.3 S2 HD MACHINES

Jaw opening adjustment.

Before adjusting the jaw opening, the operator must remove the protective case, unscrewing the rear tightening screws.



Then, loosen the hose according to the following instructions:

	<p>Remove the screw and the self-locking nut.</p>
	<p>Loosen the hose, using the specific reinforcement rod provided with the Bucket Crusher, in order to free the connecting - rod.</p>
	<p>At this point, to reduce the jaw opening, add adjustment shims, and to increase it, remove them.</p>

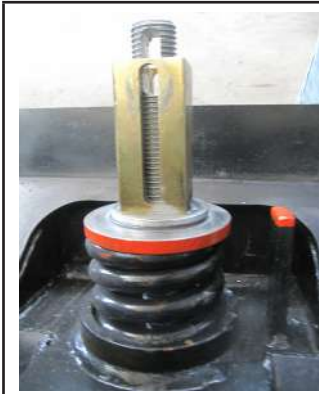

Once added the adjustment shims, retighten the hose so that the red part above the spring coincides with the red part of the indicator at the side.
Position the hose so that the safety bolt enters in the corresponding hole on the threaded bar.



Once the sizing adjustment operation is completed, check that the shims covering case is well fixed, so that they cannot escape during the crushing phase.

After adjustment, slowly turn the jaw and check that the spring has its min. and max. established range (during working, the spring must never exceed its upper max. point, shown in red).
Then, restore the protections and the protective case where the spring is located, using the fastening screws.

Flywheel regulation and fixing



ATTENTION !

Possible regulation and fixing operations of the flywheel must be done only by qualified people, authorized by the manufacturer



ADJUSTMENTS ON BF 120.4 S2 AND BF 120.4 S2 HD MACHINES

Jaw opening adjustment

Before doing the regulation, the operator must remove the protective case, unscrewing the rear tightening screws.



Then, loosen the hose according to the following instructions:

	<p>Remove the screw and the self-locking nut.</p>
	<p>Loosen the hose, using the specific wrench provided with the Bucket Crusher, in order to free the connecting - rod.</p>
	<p>At this point, to reduce the jaw opening, add adjustment shims, and to increase it, remove them.</p>
	<p>Once added the adjustment shims, retighten the hose manually with a variable force between 190 Nm and 270 Nm. Position the hose so that the safety bolt enters in the corresponding hole on the threaded bar.</p>



Once the sizing adjustment operation is completed, check that the shims covering case is well fixed, so that they cannot escape during the crushing phase.

After adjustment, slowly turn the jaw and check that the regulation pipe is fixed. Then, restore the protections and the protective case where the kinematic group is located, using the fastening screws.

Flywheel regulation and fixing



ATTENTION !

Possible regulation and fixing operations of the flywheel must be done only by qualified people, authorized by the manufacturer

5.4.1 OIL FLOW RATE ADJUSTMENT

Oil flow rate regulator adjustment

The Bucket Crusher is calibrated to a rotation (see table page 42); while working, the operator may need to vary this speed, to reach an optimal functioning and less vibrations.

The regulation flywheel is shown in the following figure.

Picture A
See Fig. B

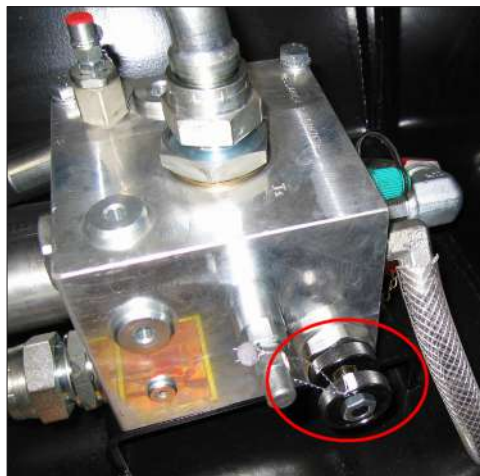

To change the shaft rotation speed, proceed as follows:

- To increase the rotation speed, turn the flywheel in counter-clockwise direction;
- To decrease the rotation speed, turn the flywheel in clockwise direction;
- To vary the speed, it is sufficient to turn the flywheel of 1/4 turn;
- Once ended the regulation phase, block the flywheel with the locking ring nut.

Picture B
See fig. A

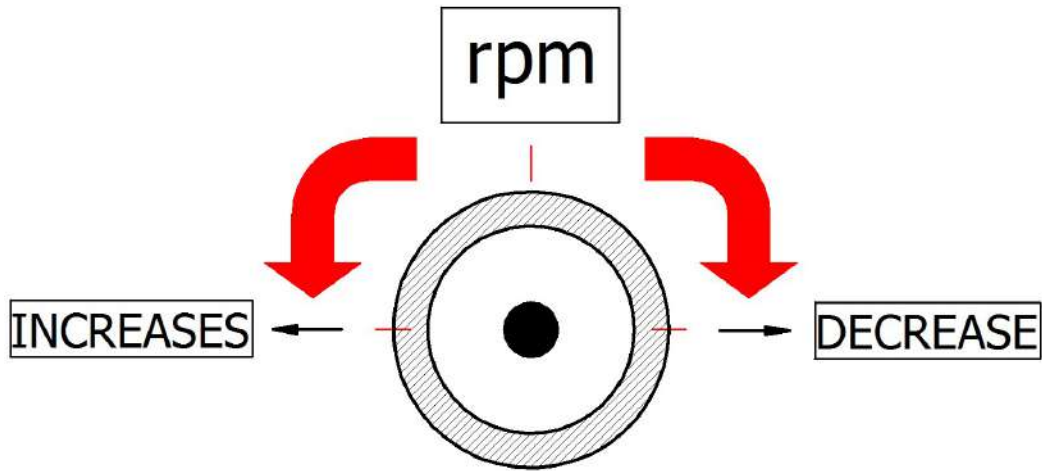

	MB-C50	BF 60.1	BF 70.2	BF 90.3 S2	BF 90.3 S2 HD	BF 120.4 S2	BF 120.4 S2 HD
<i>rpm</i> * min.	395	355	345	315	315	315	315
<i>rpm</i> * max.	405	365	355	325	325	325	325

* THE RPM ARE WITH THE BUCKET CRUSHER IN MOTION, BUT WITHOUT MATERIAL INSIDE IT.

To prevent tampering with the valve flow rates and, consequently, with the hydraulic system's operating pressures, the control valves have been leaded. In order to calculate the Bucket Crusher's rpm, put a counter near the flywheel.

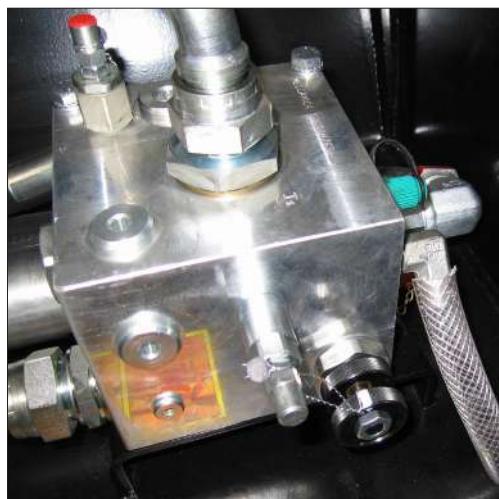

ATTENTION !

It is absolutely forbidden to tamper with the safety lead-seals. In case of tampering, MB S.p.A. is not responsible for any breakdowns, damages or injuries to properties and people.



Normally, any adjustment on the oil delivery should be required. However, if for any reason the quantity of oil that arrives from the machine tool is greater or less than the optimal required one, small adjustments to increase or decrease are permitted, within the limits of the lead seal slack. These limits must not be exceeded forcing the lead seal itself.



If during the machine's functioning the operator notices some oil escaping from the discharge hose, this means that the backpressure in the excavator's system exceeds 10 bar. In this case, check that the oil discharge (return) system on the excavator is not damaged, and check the filter on the machine, if present.

5.4.2 DRAINAGE TUBE INSTALLATION





For the Bucket Crushers equipped with drainage hydraulic system, the operator has to do as follows: in correspondence of the hydraulic connector (1), install the flexible hose of connection to the drainage system, located on the excavator's arm.



The flexible hose 3/4" gas (BSPP), or 1/2" on MB-C50 must have technical characteristics able to support a min. working pressure of 50 bar.

The connection (in all the Bucket Crusher models) for the installation of the drainage system is of 3/4" gas BSPP (male), except for MB-C50 where the connector is 1/2" gas BSPP (male).



5.4.3 BELT TENSION REGULATION

Before proceeding with the regulation or with the checking of the transmission belt, the operator must place the Bucket Crusher so that the belt upper side is horizontal as regards the bolster. Follow the sequence of indications here below:



MB-C 50

	<p>Remove all the fastening screws from the protective case, and remove it.</p>
	<p>Act on the screw to carry out the belt tensioning, using a dynamometric wrench, calibrated with a variable force equal to 35 Nm.</p>
	<p>Check that the belt is well aligned with the flywheel. Once the regulation is ended, block the guide pulley using the specific self-locking nuts. Then, reposition the protective case.</p>



BF 60.1 - BF 120.4 S2 - BF 120.4 S2 HD

	<p>Remove all the fastening screws from the protective case, and remove it.</p>
	<p>Act on the screw to carry out the belt tensioning, using a dynamometric wrench, calibrated with a variable force equal to 35 Nm.</p>
	<p>Check that the belt is well aligned with the flywheel. Once the regulation is ended, block the guide pulley using the specific self-locking nuts. Then, reposition the protective case.</p>

BF 70.2

	<p>Remove the fastening screws from the protective case, and remove it.</p>
	<p>Loosen the screws on the support unit.</p>
	<p>Act on the screws to carry out belt tensioning. Check that the same number of turns is made on both screws. Once the regulation is ended, block the fastening screws on the support.</p>

BF 90.3 S2 - BF 90.3 S2 HD

	<p>Remove the fastening screws from the protective case, and remove it.</p>
	<p>Loosen the screws on the support unit</p>
	<p>In order to tighten the belt, act on the M14 back screw.</p>

The belt is correctly tightened when, applying a perpendicular load of 25 kg in the middle of the two pulleys' axle, you obtain a flexion of 10 mm. (arrow f).
See the following figure.

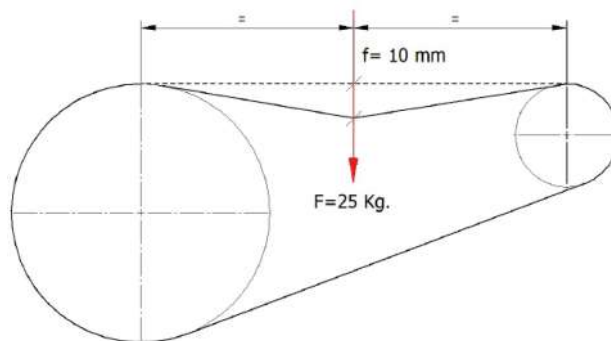

If, starting the Bucket Crusher up, the belt starts to slide on the motor pulley or on the flywheel, it means that the tightening was not done properly; therefore, repeat the above listed operations.
At this point, turn the belt slowly, in order to check that it is working in correspondence to the flywheel.



Check that the transmission belt is well aligned
(FOR ALL THE MODELS).



ATTENTION !

While checking the belt rotation, the operator must keep a safe distance from the machine.



Once ended the adjustment and control operations, the operator must reinstall the protective case before using the machine (FOR ALL THE MODELS).

6 MACHINE MAINTENANCE

6.1 GENERAL WARNINGS

DANGER !



All the control, cleaning and maintenance operations must be carried out only with stopped machine, turning the motor of the machine that moves the Bucket Crusher off and removing the start keys from the control panel.

ATTENTION !



It is strictly forbidden to remove or tamper with the machine protections, or to carry out any control, cleaning or maintenance operation with the machine tool turned on.

ATTENTION !



Before carrying out any control, cleaning or maintenance operations, the operator must put on the Personal Protective Equipment (PPE), suitable for the operation to be performed.

ATTENTION !



If any protection breaks, it must be repaired immediately in an effective manner, or be replaced and reassembled in its position before using the machine.

ATTENTION !



If any of the machine's safety components break or go wrong, it must be replaced immediately.

ATTENTION !



MB S.p.A. forbids the use of the machine in the case that all its safety components and protections are not on it, and in proper working order. The company also declines all liability in case of harms to people and/or damages to the machine or properties, for operations carried out by the operator or by a third part, that do not comply with what is indicated above.

ATTENTION !



Before starting with the control, cleaning or maintenance operations, the following operations must be carried out first:

- Turn the motor of the machine tool that moves the Bucket Crusher off, and remove the start keys from the control panel.
 - Activate the hand brake.
 - Signal the maintenance phase going on with an appropriate sign.
-

ATTENTION !



The operator has to avoid using the Crusher Bucket under unsuitable conditions or when under the influence of alcohol or drugs.

6.2 BUCKET CRUSHER MAINTENANCE



Before carrying out any maintenance, comply with the instructions contained in paragraphs 6.1 and 6.2.

The maintenance operations must be carried out by specialized people.



IT'S VERY IMPORTANT TO DISCONNECT THE POWER OF OIL TO THE MACHINE DURING MAINTENANCE.



6.2.1 PERIODICAL CHECKS

Table A contains a list of the checks that the operator must carry out after the first 8 hours of machine operation.



TABLE A			
PERIODICITY	REF	PARTS TO CHECK	OPERATIONS
<p>Repeat the checks every 8 hours during the first machine's 50 working hours.</p> <p>Then, repeat the checks every 50 working hours.</p>	1	Jaw's blocking wedge fastening screws (fixed and mobile).	Check screw tightening with a dynamometric wrench at 450 Nm.
	2	Upper connection plate's fastening screws (rear, front plate).	Check screw tightening with a dynamometric wrench at 450 Nm.
	3	Fastening screws on the couplings, on both sides.	Check screws tightening MB-C50, BF 60.1 AND BF 70.2 (at 83 Nm) - BF 90.3 S2 - BF 90.3 S2 HD - BF 120.4 S2 - BF 120.4 S2 HD (at 145 Nm).
	4	Hydraulic system.	Check possible oil leaks.
	5	Transmission belt.	Check its tension.
	6	Check spring alignment through shims' regulation hose	Spring alignment - see red indicator at side. The spring, while working, must never exceed above the red indicator.
	7	Fixing jaws of MB-C50	Check screw tightening with a dynamometric wrench at 450 Nm.

*THE PICTURES ARE PURELY INDICATIVE. THE CHECKS ARE THE SAME FOR ALL THE BUCKET CRUSHERS MODELS (SEE DETAILED TECHNICAL SPECIFICATIONS ON THE "PERIODICAL CHECKS" TABLE)

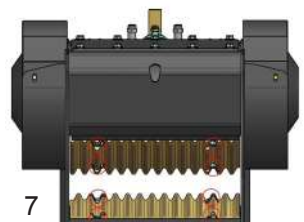
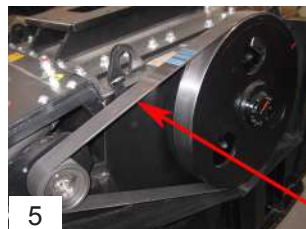
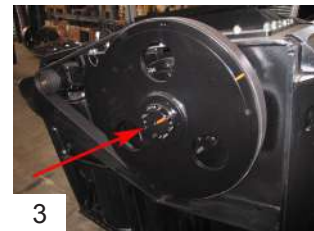

6.2.2 PERIODIC REPLACEMENT OF COMPONENTS

PERIODIC REPLACEMENT OF COMPONENTS MB-C50	
<p>The frequencies shown for replacing components should be considered with the Bucket working on SEMI HARD* materials as per the Mohs Scale*. If HARD* materials are crushed, these time parameters could reduce considerably.</p>	
Code and component	Lifetime of component before mandatory replacement
<p>101207001K - Bolts</p> <p>Failure to replace the bolts may cause the jaws to move out of position and consequently damage the supports and the rear teeth anchoring the jaw.</p>	<p>Variable. Depends on the type of material processed. However, when the material begins to damage the bolt, replace both the wedge and the bolts. In all cases, replace them whenever reversing or replacing the jaw and wedges.</p>
<p>B70006750 – Spring</p> <p>Failure to replace the spring at the indicated frequency may, in case of breakage, seriously damage the entire assembly, the cam and the Bucket structure.</p>	<p>After 500 working hours or 1 year.</p>
<p>600065501 - Belt</p>	<p>After 1000 working hours or 1 year.</p>
<p>B50001250– Cam</p> <p>Failure to replace the Cam at the indicated frequency may cause it to leave its supports and break. It may also break the jaw support and other structural components.</p>	<p>After 500 working hours.</p>
<p>B70020831- Lower nylon washer</p> <p>Failure to replace the washer at the indicated frequency may cause the spring to move incorrectly and break itself and related parts.</p>	<p>After 500 working hours.</p>
<p>249006000 - Silent block</p> <p>Failure to replace the Silent Block at the indicated frequency may cause the threaded bar to move incorrectly and break the spring and related parts.</p>	<p>After 500 working hours or 1 year.</p>
<p>L16002350 - Threaded bar</p>	<p>After 2000 working hours.</p>
<p>B70006431 - Threaded bar washer</p> <p>Failure to replace the washer at the indicated frequency may cause the spring to move incorrectly and break itself and related parts.</p>	<p>After 500 working hours.</p>
<p>L16002050 - Shrink disc</p>	<p>After 1000 working hours.</p>
<p>BF5000009 - Hydraulic control unit</p> <p>Failure to replace the gaskets may cause small but annoying oil leaks from the various connectors.</p>	<p>Replace just the gaskets after 2000 working hours or 2 years. Sharp temperature changes may damage the gaskets in even less time.</p>
<p>L16001331 - Belt tightener</p>	<p>After 1000 working hours or 1 year.</p>
<p>608009001 - Engine pulley</p>	<p>After 1000 working hours.</p>

<p>201004301 - Hydraulic engine</p> <p>Failure to replace the gaskets at the indicated frequency may lead to a serious reduction in engine power and cause oil to leak from the head and body of the engine.</p>	<p>Replace just the internal gaskets after 1000 working hours or 2 years.</p> <p>If the excavator hydraulic system is subject to back pressure faults, it may damage the gaskets in even less time.</p>
---	---

(C) Component subject to wear

All components must be replaced with original MB spares.

The use of unoriginal parts prejudices/invalidates the Warranty.

MB-C50

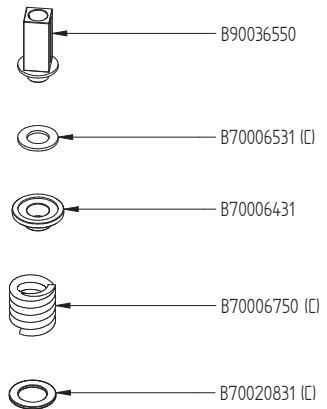
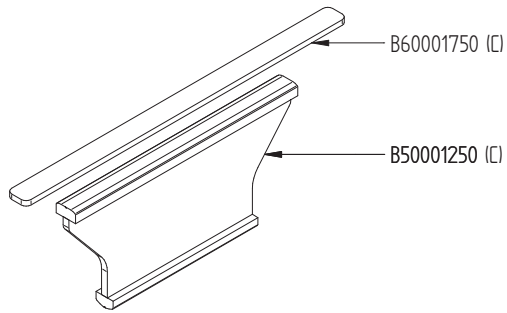
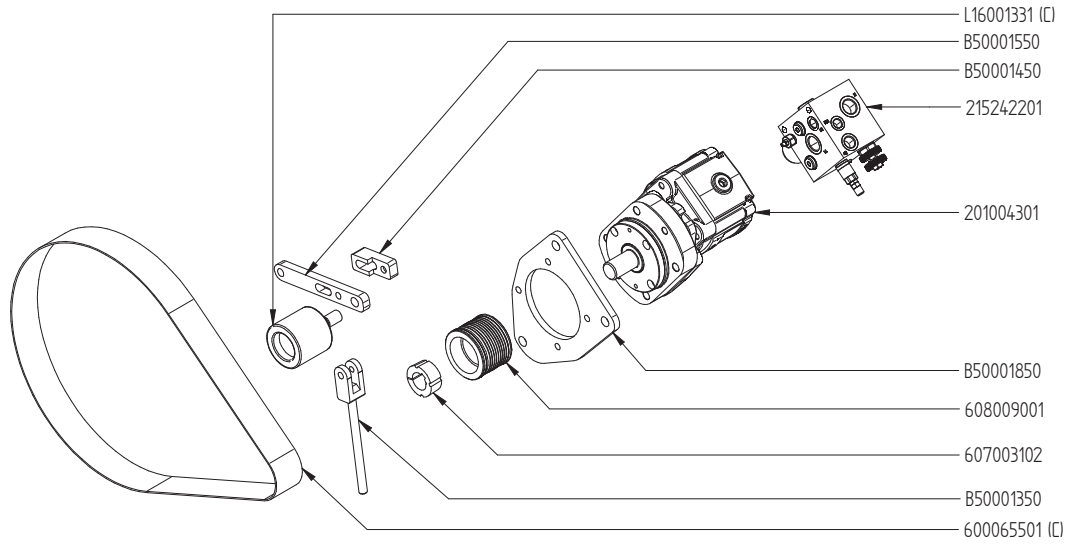

CODE	KG
L16001331 (C)	0,40
B50001550	0,60
B50001450	0,05
215242201	3,50
201004301	26,50
B50001850	2,70
608009001	1,60
607003102	0,30
B50001350	0,60
600065501 (C)	2,00
B60001750 (C)	1,90
B50001250 (C)	10,50
100207001K (C)	0,40
B50000550 (C)	62,00
B90036550	1,10
B70006531 (C)	0,10
B70006431	0,50
B70006750 (C)	1,20
B70020831 (C)	0,05
L16002350	3,90
249006000 (C)	0,60
101201201K (C)	0,50

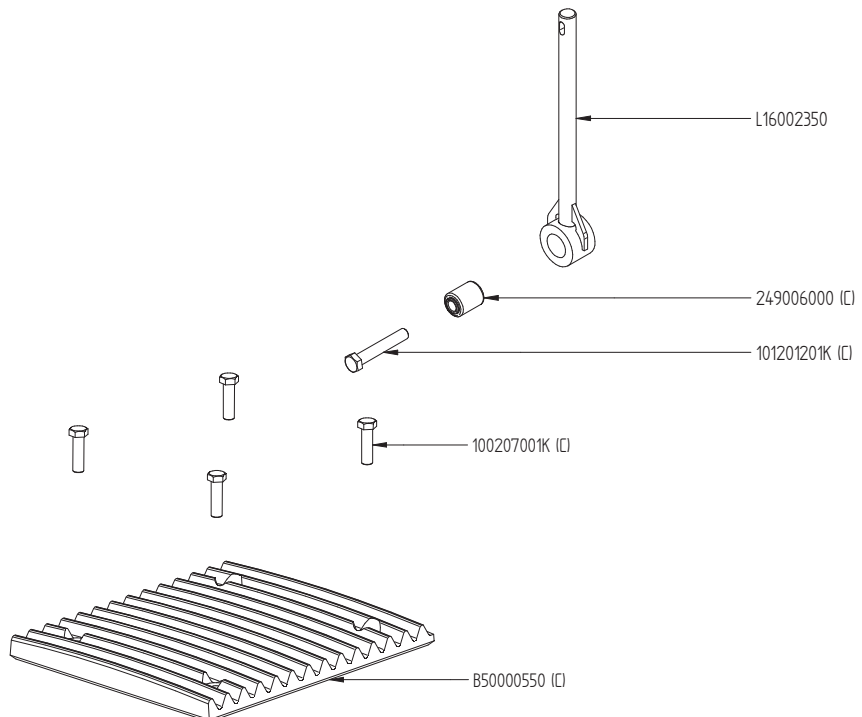

(C) WEARING PART

PERIODIC REPLACEMENT OF COMPONENTS BF 60.1	
The frequencies shown for replacing components should be considered with the Bucket working on SEMI HARD* materials as per the Mohs Scale*. If HARD* materials are crushed, these time parameters could reduce considerably.	
Code and component	Lifetime of component before mandatory replacement
<p style="text-align: center;">B60001150 - Jaws</p> <p>Failure to replace worn jaws generates excessive structural stress during crushing and reduces production capacity.</p>	<p>Variable. Depends on the type of material processed.</p> <p>In all cases, replace the component when the height of the tooth falls under 10 mm due to wear, and always if more than 40% of the surface is flattened.</p>
<p style="text-align: center;">B60001931 - Lower jaw lock wedge</p> <p>Failure to replace the worn wedge may cause the jaw bolts to move out of position and consequently damage the jaw supports and lock teeth.</p>	<p>Variable. Depends on the type of material processed.</p> <p>In all cases, replace the component when the heads of the internal bolts are almost at the same level as the outer surface of the wedge.</p>
<p style="text-align: center;">101207501K - Lower wedge bolts</p> <p>Failure to replace the bolts may cause the jaws to move out of position and consequently damage the supports and the rear teeth anchoring the jaw.</p>	<p>Variable. Depends on the type of material processed. However, when the material begins to damage the bolt, replace both the wedge and the bolts. In all cases, replace them whenever reversing or replacing the jaw and wedges.</p>
<p style="text-align: center;">101208001K - Upper wedge bolts</p> <p>Failure to replace the bolts may cause the jaws to move out of position and consequently damage the supports and the rear teeth anchoring the jaw.</p>	<p>Variable. Depends on the type of material processed. However, when the material begins to damage the bolt, replace both the wedge and the bolts. In all cases, replace them whenever reversing or replacing the jaw and wedges.</p>
<p style="text-align: center;">B70006750 - Spring</p> <p>Failure to replace the spring at the indicated frequency may, in case of breakage, seriously damage the entire assembly, the cam and the Bucket structure.</p>	<p>After 500 working hours or 1 year.</p>
B60004050 - Belt	<p>After 1000 working hours or 1 year.</p>
<p style="text-align: center;">B60008950 - Cam</p> <p>Failure to replace the Cam at the indicated frequency may cause it to leave its supports and break. It may also break the jaw support and other structural components.</p>	<p>After 500 working hours.</p>
B60003850 - Lower cam anti-wear plate	<p>After 500 working hours.</p>
<p style="text-align: center;">B70020831- Lower nylon washer</p> <p>Failure to replace the washer at the indicated frequency may cause the spring to move incorrectly and break itself and related parts.</p>	<p>After 500 working hours.</p>
<p style="text-align: center;">249006000 - Silent block</p> <p>La mancata sostituzione del Silent Block entro i termini indicati, può provocare movimenti anomali alla barra filettata con conseguenti rotture della molla e delle parti correlate.</p>	<p>After 500 working hours or 1 year.</p>
<p style="text-align: center;">B60003050 - Upper jaw lock wedge</p> <p>Failure to replace the worn wedge may cause the jaw bolts to move out of position and consequently damage the jaw supports.</p>	<p>Variable. Depends on the type of material processed.</p> <p>In all cases, replace the component when the heads of the internal bolts are almost at the same level as the outer surface of the wedge.</p>

<p>B60008850 - Threaded bar</p>	<p>After 2000 working hours.</p>
<p>B70006431 - Threaded bar washer Failure to replace the washer at the indicated frequency may cause the spring to move incorrectly and break itself and related parts.</p>	<p>After 500 working hours.</p>
<p>607005001 - Keyer</p>	<p>After 1000 working hours.</p>
<p>215225801 - Hydraulic control unit Failure to replace the gaskets may cause small but annoying oil leaks from the various connectors.</p>	<p>Replace just the gaskets after 2000 working hours or 2 years. Sharp temperature changes may damage the gaskets in even less time.</p>
<p>609005001 - Belt tightener</p>	<p>After 1000 working hours or 1 year.</p>
<p>608014002 - Engine pulley</p>	<p>After 1000 working hours.</p>
<p>201005001 - Hydraulic engine Failure to replace the gaskets at the indicated frequency may lead to a serious reduction in engine power and cause oil to leak from the head and body of the engine.</p>	<p>Replace just the internal gaskets after 1000 working hours or 2 years. If the excavator hydraulic system is subject to back pressure faults, it may damage the gaskets in even less time.</p>
<p>B60000268 - Upper jaw lock teeth</p>	<p>Variable. Depends on the type of material processed. In all cases replace the component when its thickness decreases so much that it can no longer lock the jaw.</p>
<p>B60000159 - Lower jaw lock teeth</p>	<p>Variable. Depends on the type of material processed. In all cases replace the component when its thickness decreases so much that it can no longer lock the jaw.</p>

(C) Component subject to wear

All components must be replaced with original MB spares.

The use of unoriginal parts prejudices/invalidates the Warranty.

BF60.1

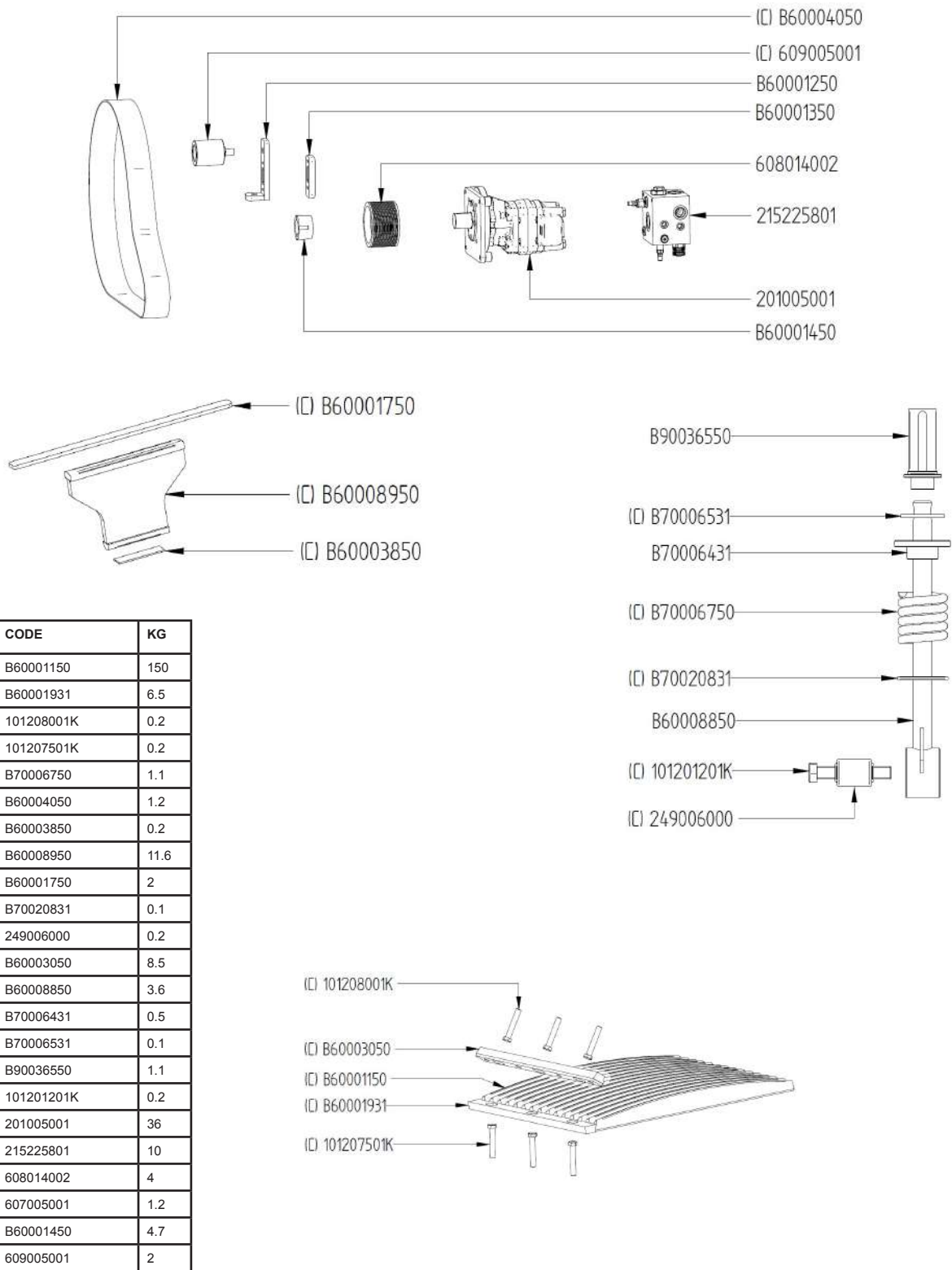

(C) WEARING PART

PERIODIC REPLACEMENT OF COMPONENTS BF 70.2

The frequencies shown for replacing components should be considered with the Bucket working on **SEMI HARD*** materials as per the Mohs Scale*. If **HARD*** materials are crushed, these time parameters could reduce considerably.

Code and component	Lifetime of component before mandatory replacement
<p>B70004250 - Jaws</p> <p>Failure to replace worn jaws generates excessive structural stress during crushing and reduces production capacity.</p>	<p>Variable. Depends on the type of material processed.</p> <p>In all cases, replace the component when the height of the tooth falls under 10 mm due to wear, and always if more than 40% of the surface is flattened.</p>
<p>B70003750 - Lower jaw lock wedge</p> <p>Failure to replace the worn wedge may cause the jaw bolts to move out of position and consequently damage the jaw supports and lock teeth.</p>	<p>Variable. Depends on the type of material processed.</p> <p>In all cases, replace the component when the heads of the internal bolts are almost at the same level as the outer surface of the wedge.</p>
<p>101207501K - Lower wedge bolts</p> <p>Failure to replace the bolts may cause the jaws to move out of position and consequently damage the supports and the rear teeth anchoring the jaw.</p>	<p>Variable. Depends on the type of material processed. However, when the material begins to damage the bolt, replace both the wedge and the bolts. In all cases, replace them whenever reversing or replacing the jaw and wedges.</p>
<p>101208001K - Upper wedge bolts</p> <p>Failure to replace the bolts may cause the jaws to move out of position and consequently damage the supports and the rear teeth anchoring the jaw.</p>	<p>Variable. Depends on the type of material processed. However, when the material begins to damage the bolt, replace both the wedge and the bolts. In all cases, replace them whenever reversing or replacing the jaw and wedges.</p>
<p>B70029050 - Spring</p> <p>Failure to replace the spring at the indicated frequency may, in case of breakage, seriously damage the entire assembly, the cam and the Bucket structure.</p>	<p>After 500 working hours or 1 year.</p>
<p>B70004850 - Belt</p>	<p>After 2000 working hours or 2 year.</p>
<p>B70007950 - Cam</p> <p>Failure to replace the Cam at the indicated frequency may cause it to leave its supports and break. It may also break the jaw support and other structural components.</p>	<p>After 500 working hours.</p>
<p>B70008050 - Lower cam plate</p>	<p>After 500 working hours.</p>
<p>B70006531 - Upper nylon washer</p> <p>Failure to replace the washer at the indicated frequency may cause the spring to move incorrectly and break itself and related parts.</p>	<p>After 500 working hours.</p>
<p>B70020831- Lower nylon washer</p> <p>Failure to replace the washer at the indicated frequency may cause the spring to move incorrectly and break itself and related parts.</p>	<p>After 500 working hours.</p>
<p>249006000 - Silent Block</p> <p>Failure to replace the Silent Block at the indicated frequency may cause the threaded bar to move incorrectly and break the spring and related parts.</p>	<p>After 500 working hours or 1 year.</p>

<p>B70008550 - Upper jaw lock wedge</p> <p>Failure to replace the worn wedge may cause the jaw bolts to move out of position and consequently damage the jaw supports.</p>	<p>Variable. Depends on the type of material processed.</p> <p>In all cases, replace the component when the heads of the internal bolts are almost at the same level as the outer surface of the wedge.</p>
<p>B70020950 - Threaded bar</p>	<p>After 2000 working hours.</p>
<p>607005001 - Keyer</p>	<p>After 1000 working hours.</p>
<p>215225801- Hydraulic control unit</p> <p>Failure to replace the gaskets may cause small but annoying oil leaks from the various connectors.</p>	<p>Replace just the gaskets after 2000 working hours or 2 years.</p> <p>Sharp temperature changes may damage the gaskets in even less time.</p>
<p>608014002 - Engine pulley</p>	<p>After 1000 working hours.</p>
<p>201007101 - Hydraulic engine</p> <p>Failure to replace the gaskets at the indicated frequency may lead to a serious reduction in engine power and cause oil to leak from the head and body of the engine.</p>	<p>Replace just the internal gaskets after 1000 working hours or 2 years.</p> <p>If the excavator hydraulic system is subject to back pressure faults, it may damage the gaskets in even less time.</p>
<p>B70000268 - Upper jaw lock teeth</p>	<p>Variable. Depends on the type of material processed.</p> <p>In all cases replace the component when its thickness decreases so much that it can no longer lock the jaw.</p>
<p>B70000159 - Lower jaw lock teeth</p>	<p>Variable. Depends on the type of material processed.</p> <p>In all cases replace the component when its thickness decreases so much that it can no longer lock the jaw.</p>

(C) Component subject to wear

All components must be replaced with original MB spares.

The use of unoriginal parts prejudices/invalidates the Warranty.

BF70.2

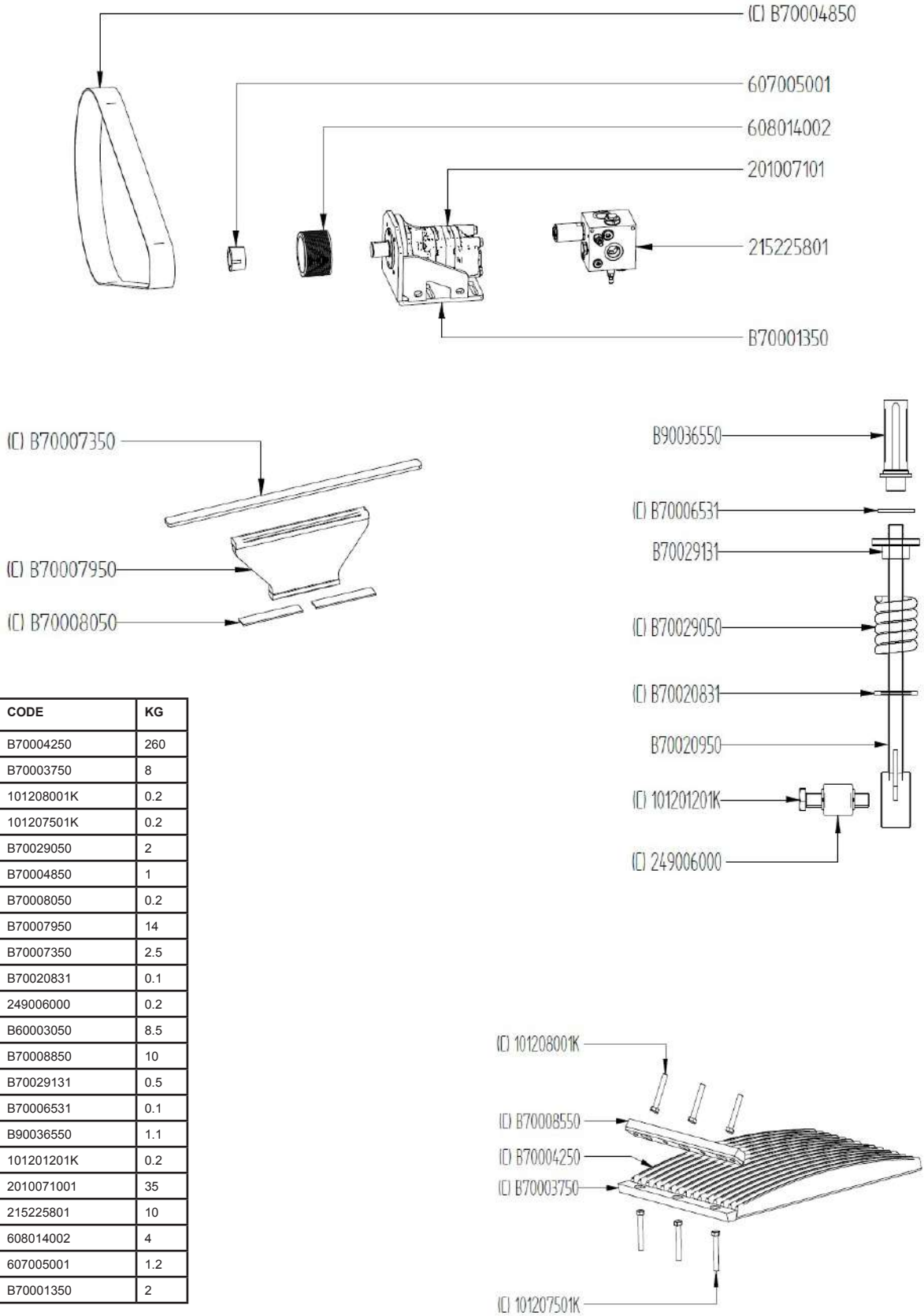

CODE	KG
B70004250	260
B70003750	8
101208001K	0.2
101207501K	0.2
B70029050	2
B70004850	1
B70008050	0.2
B70007950	14
B70007350	2.5
B70020831	0.1
249006000	0.2
B60003050	8.5
B70008850	10
B70029131	0.5
B70006531	0.1
B90036550	1.1
101201201K	0.2
2010071001	35
215225801	10
608014002	4
607005001	1.2
B70001350	2

(C) WEARING PART

PERIODIC REPLACEMENT OF COMPONENTS BF 90.3 S2 AND BF 90.3 S2 HD

The frequencies shown for replacing components should be considered with the Bucket working on **SEMI HARD*** materials as per the Mohs Scale*. If **HARD*** materials are crushed, these time parameters could reduce considerably.

Code and component	Lifetime of component before mandatory replacement
<p>249000550 - Jaws</p> <p>Failure to replace worn jaws generates excessive structural stress during crushing and reduces production capacity.</p>	<p>Variable. Depends on the type of material processed.</p> <p>In all cases, replace the component when the height of the tooth falls under 10 mm due to wear, and always if more than 40% of the surface is flattened.</p>
<p>249000650 - Lower jaw lock wedge</p> <p>Failure to replace the worn wedge may cause the jaw bolts to move out of position and consequently damage the jaw supports and lock teeth.</p>	<p>Variable. Depends on the type of material processed.</p> <p>In all cases, replace the component when the heads of the internal bolts are almost at the same level as the outer surface of the wedge.</p>
<p>101201101K - Lower wedge bolts</p> <p>Failure to replace the bolts may cause the jaws to move out of position and consequently damage the supports and the rear teeth anchoring the jaw.</p>	<p>Variable. Depends on the type of material processed. However, when the material begins to damage the bolt, replace both the wedge and the bolts. In all cases, replace them whenever reversing or replacing the jaw and wedges.</p>
<p>101010001K - Upper wedge bolts</p> <p>Failure to replace the bolts may cause the jaws to move out of position and consequently damage the supports and the rear teeth anchoring the jaw.</p>	<p>Variable. Depends on the type of material processed. However, when the material begins to damage the bolt, replace both the wedge and the bolts. In all cases, replace them whenever reversing or replacing the jaw and wedges.</p>
<p>B90022150 – Spring</p> <p>Failure to replace the spring at the indicated frequency may, in case of breakage, seriously damage the entire assembly, the cam and the Bucket structure.</p>	<p>After 500 working hours or 1 year.</p>
<p>B90036050 - Belt</p>	<p>After 1000 working hours or 2 years.</p>
<p>B90037550 - Upper cam support</p> <p>Failure to replace the upper cam support at the indicated frequency may, in case of breakage, cause serious damage to the Cam and to the jaw support and structure of the Bucket.</p>	<p>After 500 working hours.</p>
<p>B90014450 - Cam</p> <p>Failure to replace the Cam at the indicated frequency may cause it to leave its supports and break. It may also break the jaw support and other structural components.</p>	<p>After 500 working hours.</p>
<p>B90037450 - Lower cam plate</p>	<p>After 500 working hours.</p>
<p>B90033031 - Lower nylon washer</p> <p>Failure to replace the washer at the indicated frequency may cause the spring to move incorrectly and break itself and related parts.</p>	<p>After 500 working hours.</p>

<p>B70006531 - Adjustment hose washer</p> <p>Failure to replace the washer at the indicated frequency may cause the spring to move incorrectly and break itself and related parts.</p>	<p>After 500 working hours or 1 year.</p>
<p>249006000 - Silent Block</p> <p>Failure to replace the Silent Block at the indicated frequency may cause the threaded bar to move incorrectly and break the spring and related parts.</p>	<p>After 500 working hours or 1 year.</p>
<p>249015250 - Upper jaw lock wedge</p> <p>Failure to replace the worn wedge may cause the jaw bolts to move out of position and consequently damage the jaw supports.</p>	<p>Variable. Depends on the type of material processed.</p> <p>In all cases, replace the component when the heads of the internal bolts are almost at the same level as the outer surface of the wedge.</p>
<p>B90018050 - Threaded bar</p>	<p>After 2000 working hours.</p>
<p>607005001 - Keyer</p>	<p>After 1000 working hours.</p>
<p>215225801 - Hydraulic control unit</p> <p>Failure to replace the gaskets may cause small but annoying oil leaks from the various connectors.</p>	<p>Replace just the gaskets after 2000 working hours or 2 years.</p> <p>Sharp temperature changes may damage the gaskets in even less time.</p>
<p>608014002 - Engine pulley</p>	<p>After 1000 working hours.</p>
<p>201010001 - Hydraulic engine</p> <p>Failure to replace the gaskets at the indicated frequency may lead to a serious reduction in engine power and cause oil to leak from the head and body of the engine.</p>	<p>Replace just the internal gaskets after 1000 working hours or 2 years.</p> <p>If the excavator hydraulic system is subject to back pressure faults, it may damage the gaskets in even less time.</p>
<p>B90001461 - Upper jaw lock teeth</p>	<p>Variable. Depends on the type of material processed.</p> <p>In all cases replace the component when its thickness decreases so much that it can no longer lock the jaw.</p>
<p>B90002060 - Lower jaw lock teeth</p>	<p>Variable. Depends on the type of material processed.</p> <p>In all cases replace the component when its thickness decreases so much that it can no longer lock the jaw.</p>

(C) Component subject to wear

All components must be replaced with original MB spares.

The use of unoriginal parts prejudices/invalidates the Warranty.

BF90.3 S2 - BF90.3 S2 HD

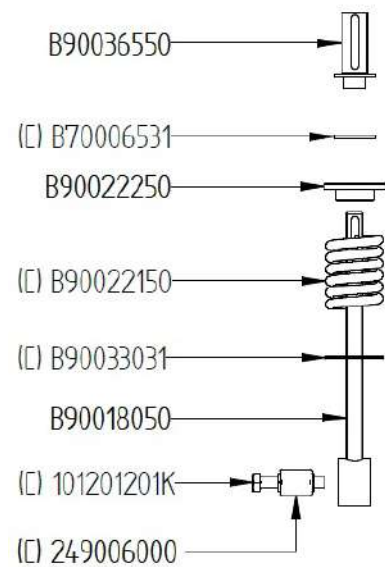
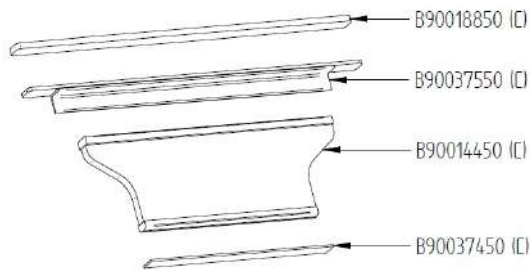
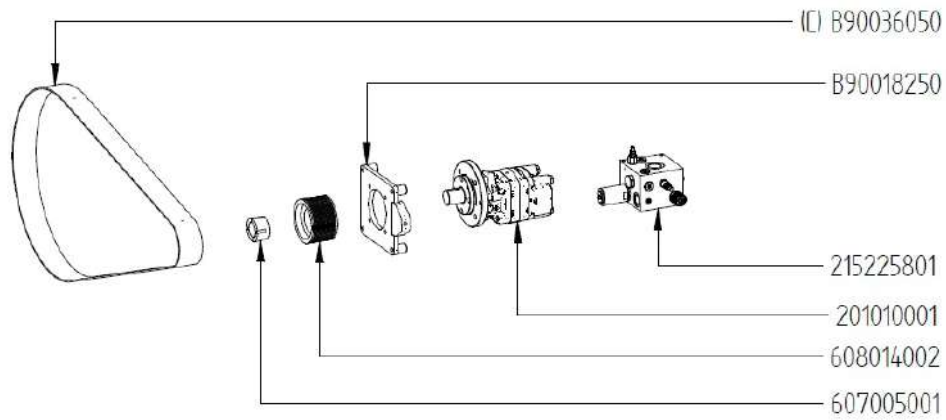

CODE	KG
249000550	300
249000650	17.8
101010001K	0.2
101201101K	0.2
B90036050	1.7
B90037450	0.8
B90014450	28
B90037550	5
B90018850	4.8
101201201K	0.2
201010001	36
B90018250	6.5
249015250	21.9
249006000	0.2
B90018050	3.8
B90033031	0.1
B90022150	1.5
B90022250	0.8
B70006531	0.1
215225801	15
608014002	4
607005001	1.2

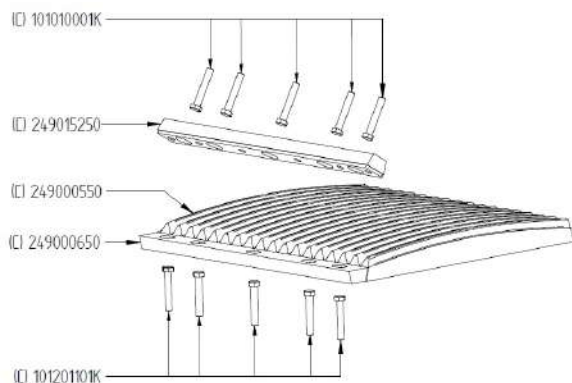

(C) WEARING PART

PERIODIC REPLACEMENT OF COMPONENTS BF 120.4 S2 AND BF 120.4 S2 HD

The frequencies shown for replacing components should be considered with the Bucket working on **SEMI HARD*** materials as per the Mohs Scale*. If **HARD*** materials are crushed, these time parameters could reduce considerably.

Code and component	Lifetime of component before mandatory replacement
<p>B12020050 - Jaws</p> <p>Failure to replace worn jaws generates excessive structural stress during crushing and reduces production capacity.</p>	<p>Variable. Depends on the type of material processed.</p> <p>In all cases, replace the component when the height of the tooth falls under 10 mm due to wear, and always if more than 40% of the surface is flattened.</p>
<p>B12003350 - Lower jaw lock wedge</p> <p>Failure to replace the worn wedge may cause the jaw bolts to move out of position and consequently damage the jaw supports and lock teeth.</p>	<p>Variable. Depends on the type of material processed.</p> <p>In all cases, replace the component when the heads of the internal bolts are almost at the same level as the outer surface of the wedge.</p>
<p>101201101K - Lower wedge bolts</p> <p>Failure to replace the bolts may cause the jaws to move out of position and consequently damage the supports and the rear teeth anchoring the jaw.</p>	<p>Variable. Depends on the type of material processed. However, when the material begins to damage the bolt, replace both the wedge and the bolts. In all cases, replace them whenever reversing or replacing the jaw and wedges.</p>
<p>101010001K - Upper wedge bolts</p> <p>Failure to replace the bolts may cause the jaws to move out of position and consequently damage the supports and the rear teeth anchoring the jaw.</p>	<p>Variable. Depends on the type of material processed. However, when the material begins to damage the bolt, replace both the wedge and the bolts. In all cases, replace them whenever reversing or replacing the jaw and wedges.</p>
<p>B90022150 - Spring</p> <p>Failure to replace the spring at the indicated frequency may, in case of breakage, seriously damage the entire assembly, the cam and the Bucket structure.</p>	<p>After 500 working hours or 1 year.</p>
<p>249004800 - Belt</p>	<p>After 1000 working hours or 2 years.</p>
<p>B12018350 - Upper cam support</p> <p>Failure to replace the upper cam support at the indicated frequency may, in case of breakage, cause serious damage to the Cam and to the jaw support and structure of the Bucket.</p>	<p>After 500 working hours.</p>
<p>B12018250 - Cam</p> <p>Failure to replace the Cam at the indicated frequency may cause it to leave its supports and break. It may also break the jaw support and other structural components.</p>	<p>After 500 working hours.</p>
<p>B12018150 - Lower cam plate</p>	<p>After 500 working hours.</p>
<p>B90033031 - Lower nylon washer</p> <p>Failure to replace the washer at the indicated frequency may cause the spring to move incorrectly and break itself and related parts.</p>	<p>After 500 working hours.</p>

<p>B70006531 - Adjustment hose washer</p> <p>Failure to replace the washer at the indicated frequency may cause the spring to move incorrectly and break itself and related parts.</p>	<p>After 500 working hours or 1 year.</p>
<p>249006000 - Silent Block</p> <p>Failure to replace the Silent Block at the indicated frequency may cause the threaded bar to move incorrectly and break the spring and related parts.</p>	<p>After 500 working hours or 1 year.</p>
<p>B12005150 - Upper jaw lock wedge</p> <p>Failure to replace the worn wedge may cause the jaw bolts to move out of position and consequently damage the jaw supports.</p>	<p>Variable. Depends on the type of material processed.</p> <p>In all cases, replace the component when the heads of the internal bolts are almost at the same level as the outer surface of the wedge.</p>
<p>B90018050 - Threaded bar</p>	<p>After 2000 working hours.</p>
<p>607005001 - Keyer</p>	<p>After 1000 working hours.</p>
<p>215225801 - Hydraulic control unit</p> <p>Failure to replace the gaskets may cause small but annoying oil leaks from the various connectors.</p>	<p>Replace just the gaskets after 2000 working hours or 2 years.</p> <p>Sharp temperature changes may damage the gaskets in even less time.</p>
<p>608014002 - Engine pulley</p>	<p>After 1000 working hours.</p>
<p>201010001 - Hydraulic engine</p> <p>Failure to replace the gaskets at the indicated frequency may lead to a serious reduction in engine power and cause oil to leak from the head and body of the engine.</p>	<p>Replace just the internal gaskets after 1000 working hours or 2 years.</p> <p>If the excavator hydraulic system is subject to back pressure faults, it may damage the gaskets in even less time.</p>
<p>609005001 - Belt tensioner</p>	<p>After 500 working hours or 1 year.</p>
<p>B90001461 - Upper jaw lock teeth</p>	<p>Variable. Depends on the type of material processed.</p> <p>In all cases replace the component when its thickness decreases so much that it can no longer lock the jaw.</p>
<p>B90002060 - Upper jaw lock teeth</p>	<p>Variable. Depends on the type of material processed.</p> <p>In all cases replace the component when its thickness decreases so much that it can no longer lock the jaw.</p>

(C) Component subject to wear

All components must be replaced with original MB spares.

The use of unoriginal parts prejudices/invalidates the Warranty.

BF120.4 S2 - BF120.4 S2 HD

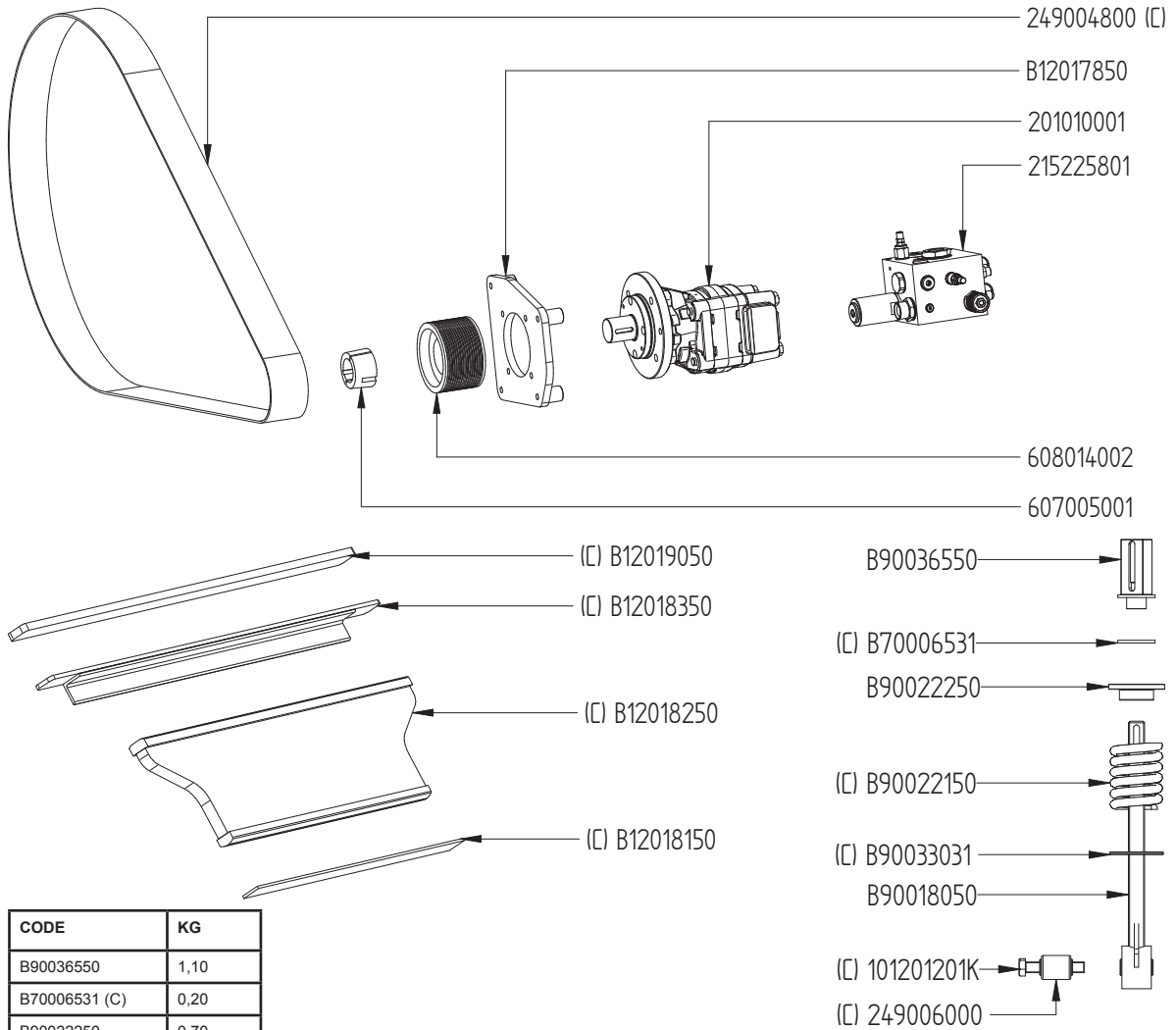

CODE	KG
B90036550	1,10
B70006531 (C)	0,20
B90022250	0,70
B90022150 (C)	2,00
B90033031 (C)	0,10
B90018050	3,00
101201201K (C)	0,50
249006000 (C)	0,60
B12019050 (C)	6,40
B12018350 (C)	5,10
B12018250 (C)	41,70
B12018150 (C)	1,20
101010001K (C)	0,70
B12005150 (C)	14,10
B12020050 (C)	375
B12003350 (C)	11,40
101201101K (C)	0,70
249004800 (C)	1,50
B12017850	5,80
201010001	35,60
215225801	20,00
608014002	5,30
607005001	0,9

(C) WEARING PART

6.2.3 ROUTINE MAINTENANCE

The TABLE B shows all the operations to be done with fixed maturity, in order to guarantee the machine's correct functioning.

TABLE B			
PERIODICITY	REF	PARTS	OPERATIONS TO DO
Every 10 working hours, in the first 100 working hours.	1	Shaft – bearing's lubricators	Inject grease.
	2	Shaft – bearing's lubricators	Inject grease.
Then, inject grease through lubricators 1 and 2 on the shaft – bearings every 30 working hours.			
All the maintenances have to be done at least once a year, even if there are no working hours enough. The reference numbers of each operation correspond to the maintenance scheme represented on the picture here below.			
LUBRICATOR MB-C50		LUBRICATOR BF 60.1 - 70.2	LUBRICATOR BF 90.3 S2/HD - BF 120.4 S2/HD
			
In order to grease the bearings inside the machine's structure, the operator must remove the two protections on the upper part of the hooking plate on models BF 90 HD and BF 120 HD. Near each opening, there are two grease boxes where the operator, using a manual lubricator, must put the grease. The access is on the contrary direct for all other models of bucket.			
NB. : the operator must grease the Bucket Crusher with 20 pumps for each bearing, at max. every 30 working hours.			
If some grease leaves from the outlet, provide to grease only the bearings on the lateral supports.			
To grease, we suggest to use AGIP GR30 grease.			

TABLE A - LUBRIFICANT GREASE		
PRODUCER	GREASE	TEMPERATURE
AGIP	AGIP GR30	243 K / 393 K (-30°C / +120°C)
BP	ENERGREASE LS-ES 2	248 K / 413 K (-25°C / +140°C)
CASTROL	SPHEEROL EPL 2	253 K / 393 K (-20°C / +120°C)
ELF	EPEXA 2	243 K / 393 K (-30°C / +120°C)
ESSO	BEACON EP 2	253 K / 393 K (-20°C / +120°C)
IP	ATHESIA EP 2	248 K / 373 K (-25°C / +100°C)
MOBIL	MOBILUX EP 2	253 K / 398 K (-20°C / +120°C)
KUBLER LUBRIFICATION	CENTOPLEX 2 EP	248 K / 403 K (-25°C / +130°C)
SHELL	SHELL ALVANIA EP 2	248 K / 403 K (-25°C / +130°C)

7 HEAVY COMPONENTS - WEIGHT OF SINGLE COMPONENTS

7.1 MB-C 50

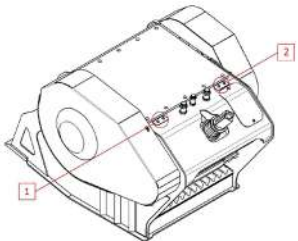
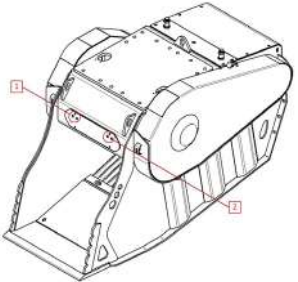
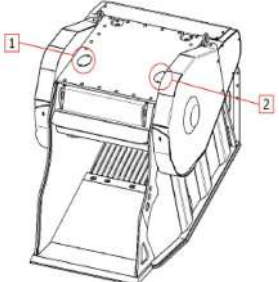
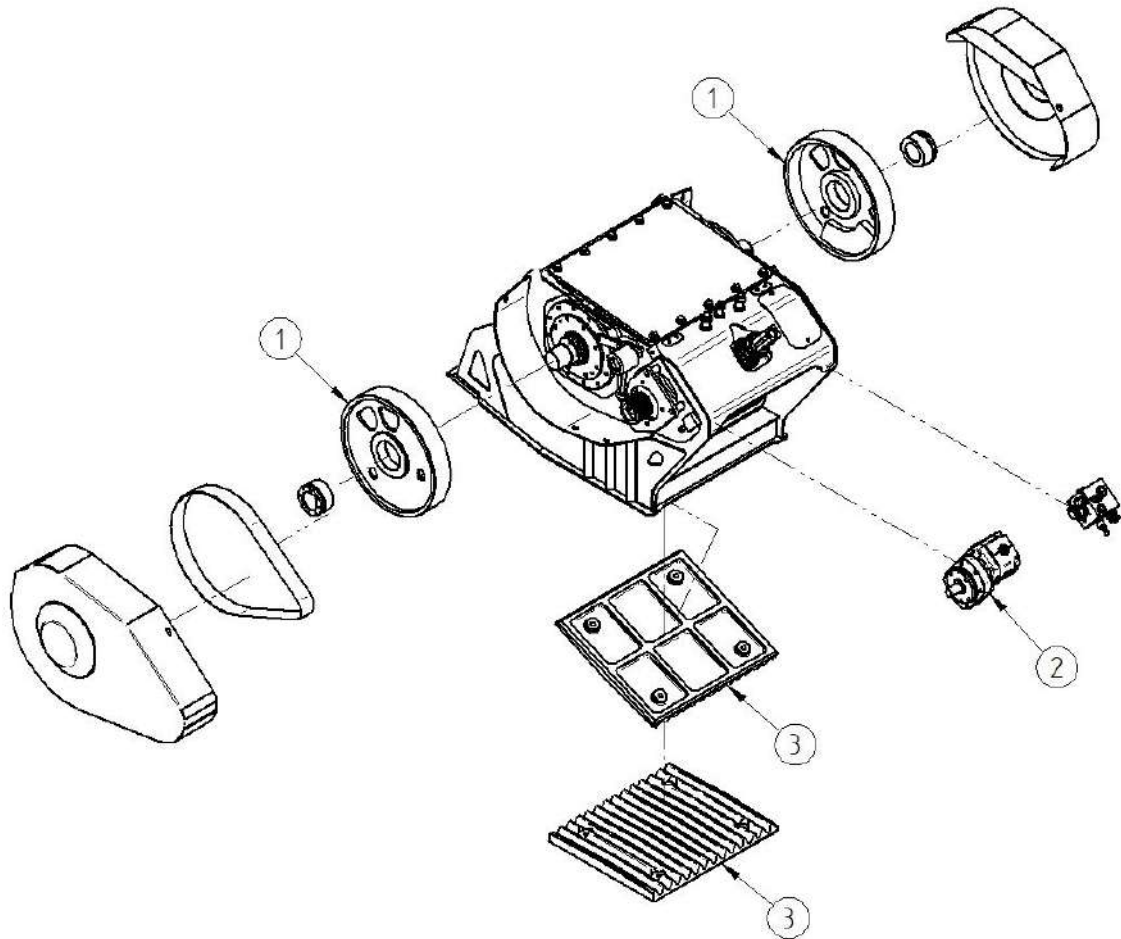

Ref. on drawing	Code	Description	Weight Kg
1	B50001731	Flywheel	30
2	201004301	Hydraulic Motor	26,5
3	B50000550	Jaw	62

The company MB S.p.A. invites to pay the maximum attention while moving parts whose weight is over 10 kg.

It is compulsory to use the personal protection's tools and, if necessary, we kindly invite you to use any tool whose function is to lift heavy components, paying attention to the risks linked to the moving of those components.

7.2 BF60.1

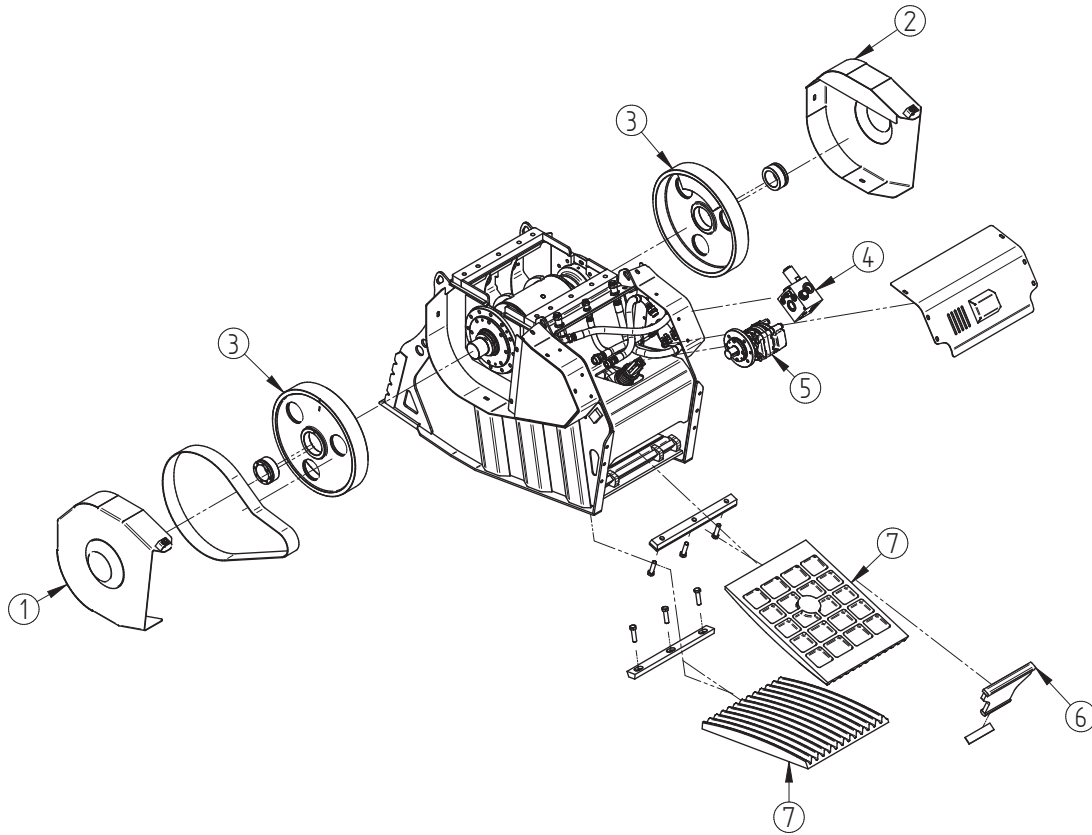

Ref. on drawing	Code	Description	Weight Kg
1	B60002350	Flywheel protection right	17
2	B60002450	Flywheel protection left	29
3	B70001150	Flywheel	72
4	215225801	Hydraulic box	19
5	201005001	Hydraulic motor	35.6
6	B60008950	Connecting rod	11.6
7	B60001150	Jaw	150

The company MB S.p.A. invites to pay the maximum attention while moving parts whose weight is over 10 kg.

It is compulsory to use the personal protection's tools and, if necessary, we kindly invite you to use any tool whose function is to lift heavy components, paying attention to the risks linked to the moving of those components.

7.3 BF70.2

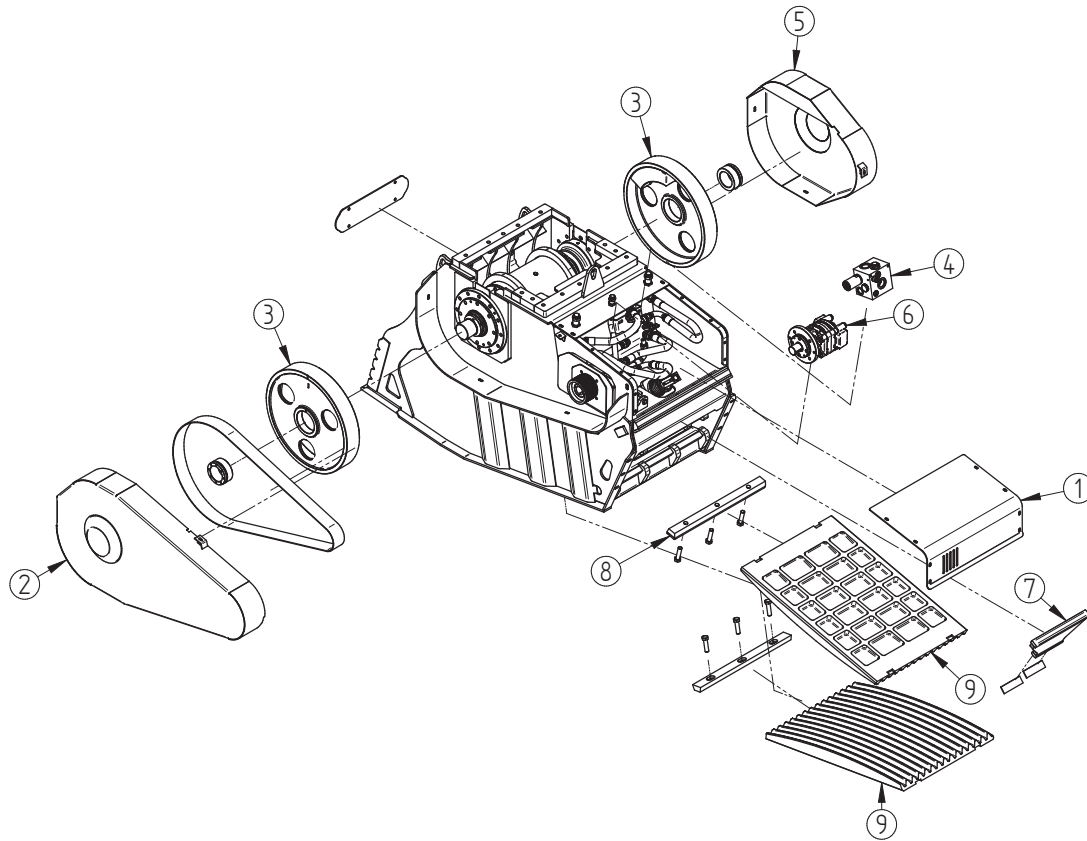

Ref. on drawing	Code	Description	Weight Kg
1	B70002150	Rear motor protection	18
2	B70002250	Right flywheel protection	29
3	B70001150	Flywheel	72
4	215225801	Hydraulic box	19
5	B70002350	Left flywheel protection	20
6	201007001	Hydraulic motor	36
7	B70007950	Connectin rod	14
8	B70008550	Upper wedge	10.2
9	B70004250	Jaw	255

The company MB S.p.A. invites to pay the maximum attention while moving parts whose weight is over 10 kg.

It is compulsory to use the personal protection's tools and, if necessary, we kindly invite you to use any tool whose function is to lift heavy components, paying attention to the risks linked to the moving of those components.

7.4 BF90.3 S2 - BF90.3 S2 HD

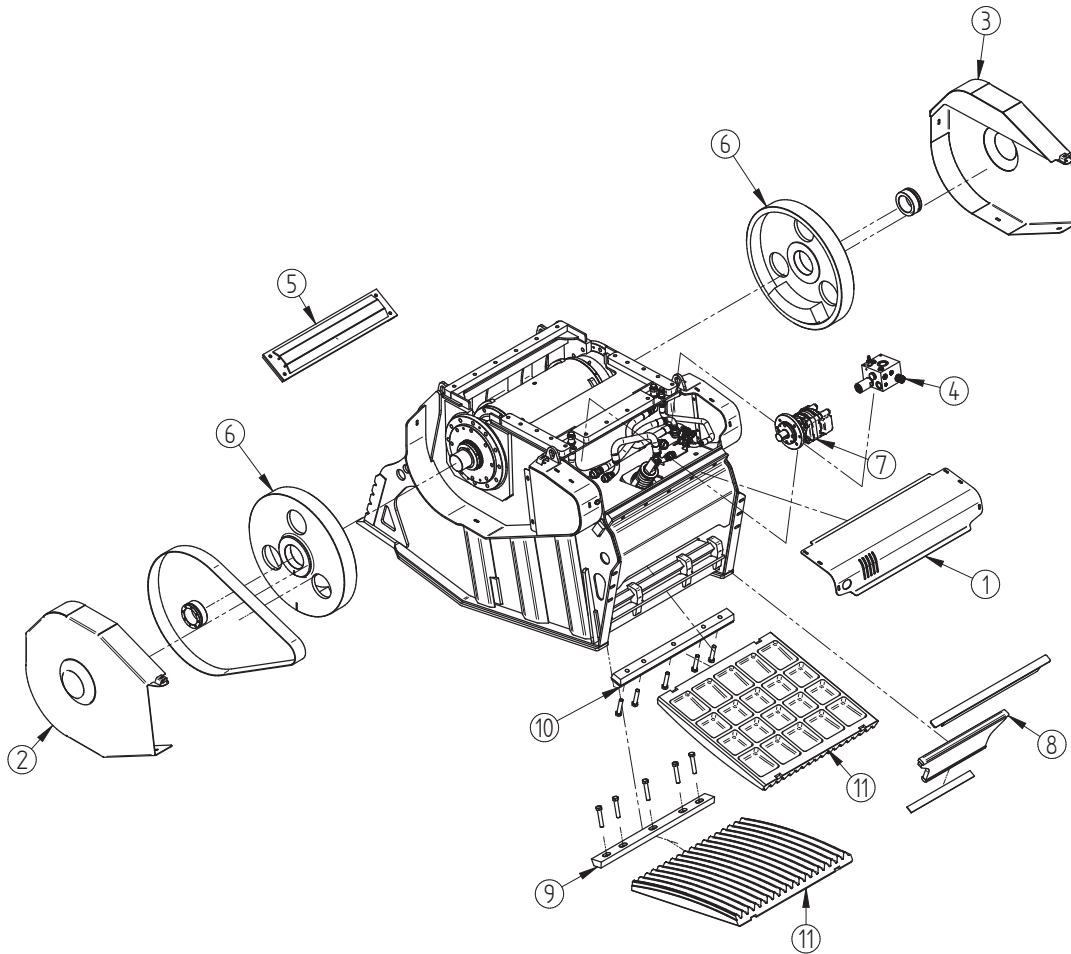

Ref. on drawing	Code	Description	Weight Kg
1	B90018350	Rear motor protection	19.6
2	B90018450	Right flywheel protection	27
3	B90018550	Left flywheel protection	29
4	215225801	Hydraulic box	19
5	249012150	Front protection	24
6	249001550	Flywheel	134
7	201010001	Hydraulic motor	35.6
8	B90014450	Connecting rod	28
9	249000650	Lower Wedge	17
10	249015250	Upper Wedge	21
11	249000550	Jaw	300

The company MB S.p.A. invites to pay the maximum attention while moving parts whose weight is over 10 kg.

It is compulsory to use the personal protection's tools and, if necessary, we kindly invite you to use any tool whose function is to lift heavy components, paying attention to the risks linked to the moving of those components.

7.5 BF120.4 S2- BF120.4 S2 HD

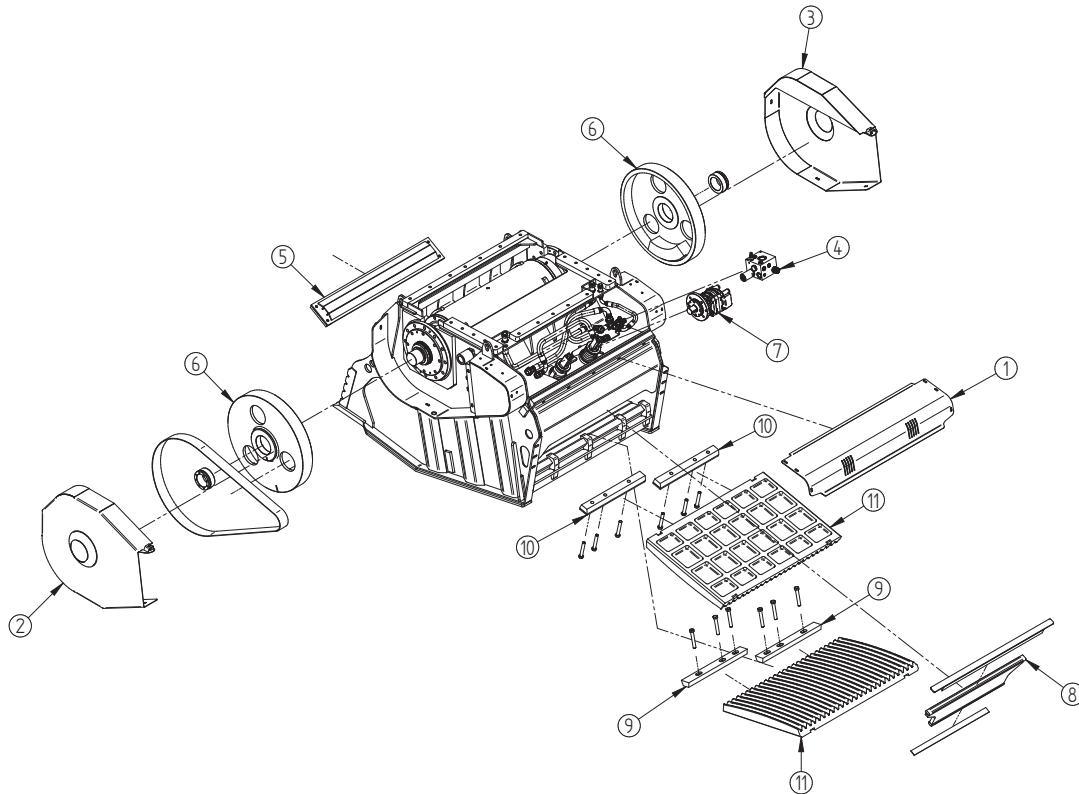

Ref. on drawing	Code	Description	Weight Kg
1	B12018750	Rear motor protection	25
2	B90018450	Right flywheel protection	27
3	B90018550	Left flywheel protection	29
4	215225801	Hydraulic box	19
5	B12018450	Front carter	24
6	249001550	Flywheel	134
7	201010001	Hydraulic motor	35.6
8	B12018250	Connecting rod	41.6
9	B12003350	Lower wedge	11.4
10	B12005150	Upper wedge	11.4
11	B12020050	Jaw	360

The company MB S.p.A. invites to pay the maximum attention while moving parts whose weight is over 10 kg.

It is compulsory to use the personal protection's tools and, if necessary, we kindly invite you to use any tool whose function is to lift heavy components, paying attention to the risks linked to the moving of those components.

8 MACHINE DEMOLITION

8.1 WASTE DISPOSAL

The machine's working phase does not generate waste or rubbish that must be recycled or disposed of, according to the laws in force in the Country of use.

If a part has to be replaced, or when the machine has to be scrapped, the elements used for the equipment (oil, rubber tubes, etc.) must be brought to an authorized disposal center, in compliance with the requirements of the current applicable law in the machine's Country of use.



ATTENTION !

MB S.p.A. declines all liability in case the customer does not use authorized centers for the machine's equipment disposal.

8.2 MACHINE DEMOLITION

When the machine has to be scrapped (for any reason, limited use, impossibility of repair, or others), it is necessary to:

- Wash the machine thoroughly, with a water jet;
- Drain the oil from the hydraulic circuit, and place it in a specific vessel;
- Remove the flexible hoses from the hydraulic system;
- Dismantle the machine's parts as possible (cases, etc.), dividing them upon type (ex. rubber components, ferrous material, etc...).



ATTENTION !

Any irregularity committed by the customer before, during or after the machine's components scrapping and disposal phases, with regard to the interpretation and application of the current laws in force, is of exclusive responsibility of the same.

CRUSHER BUCKET (MB-C50) DRAINAGE HYDRAULIC SCHEME cod. MBC50S002

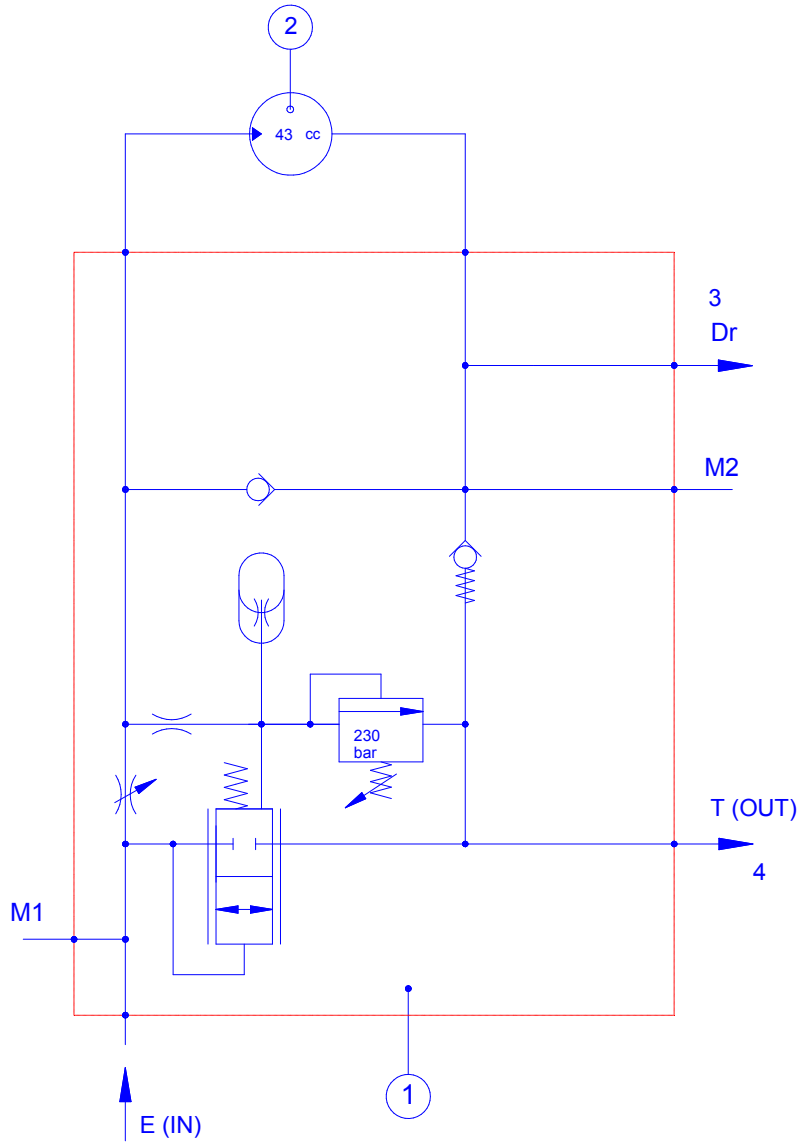

REF.	NAME
1	Capacity regulator group - Maximum output pressure valve 230 bar - Maximum capacity 140 litri/1" - Minimum working capacity 90 litri/1"
2	Hydraulic Motor 43 cc.
M1	Output pressure control hold
M2	Return counter pressure control hold
3	Drain (maximum return counter pressure 10 bar)
4	Maximum return counter pressure 10 bar

CRUSHER BUCKET (BF 60)

DRAINAGE HYDRAULIC SCHEME cod. MB60S0002

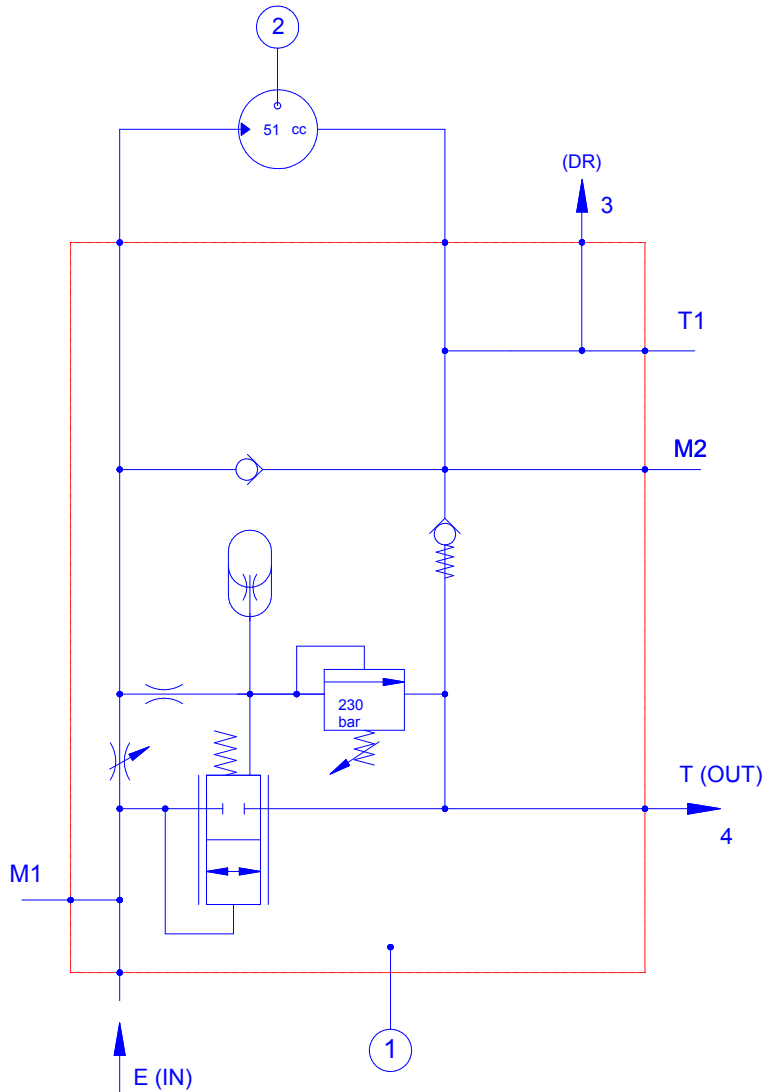

REF.	NAME
1	Capacity regulator group - Maximum output pressure valve 230 bar - Maximum capacity 280 litri/1" - Minimum working capacity 98 litri/1"
2	Hydraulic Motor 51 cc.
T1	Oil drain safety
M1	Output pressure control hold
M2	Return counter pressure control hold
3	Drain (maximum return counter pressure 10 bar)
4	Maximum return counter pressure 10 bar

CRUSHER BUCKET (BF 70)

DRAINAGE HYDRAULIC SCHEME cod. MB70S0002

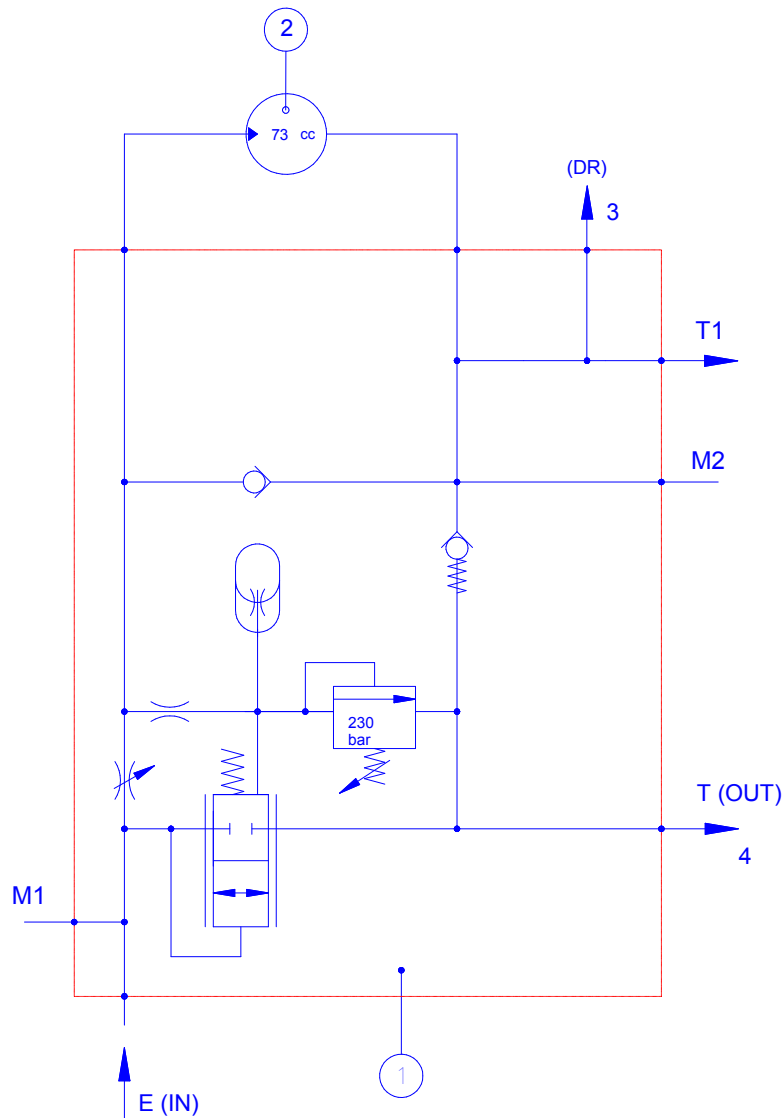

REF.	NAME
1	Capacity regulator group - Maximum output pressure valve 230 bar - Maximum capacity 280 litri/1" - Minimum working capacity 130 litri/1"
2	Hydraulic Motor 73 cc.
T1	Oil drain safety
M1	Output pressure control hold
M2	Return counter pressure control hold
3	Drain (maximum return counter pressure 10 bar)
4	Maximum return counter pressure 10 bar

CRUSHER BUCKET (BF 90 S2)

DRAINAGE HYDRAULIC SCHEME cod. MB90S0002

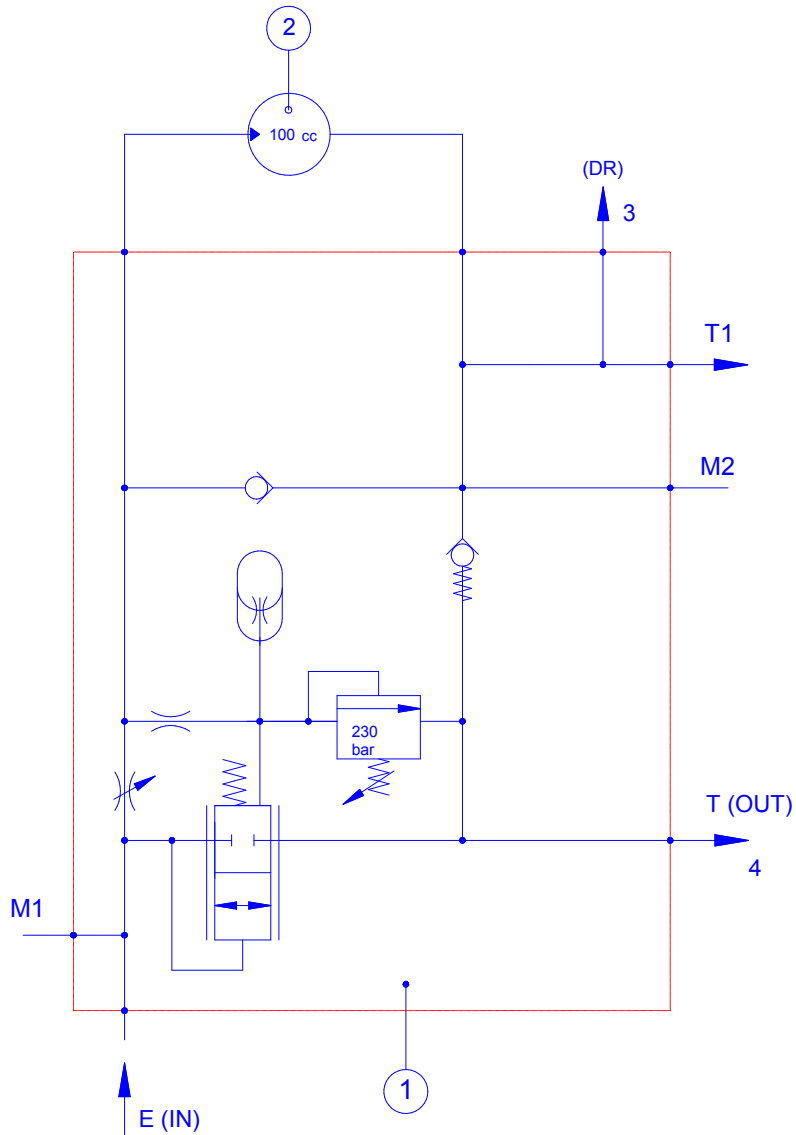

REF.	NAME
1	Capacity regulator group - Maximum output pressure valve 230 bar - Maximum capacity 280 litri/1" - Minimum working capacity 170 litri/1"
2	Hydraulic Motor 100 cc.
T1	Oil drain safety
M1	Output pressure control hold
M2	Return counter pressure control hold
3	Drain (maximum return counter pressure 10 bar)
4	Maximum return counter pressure 10 bar

CRUSHER BUCKET (BF 120 S2)

DRAINAGE HYDRAULIC SCHEME cod. MB120S0002

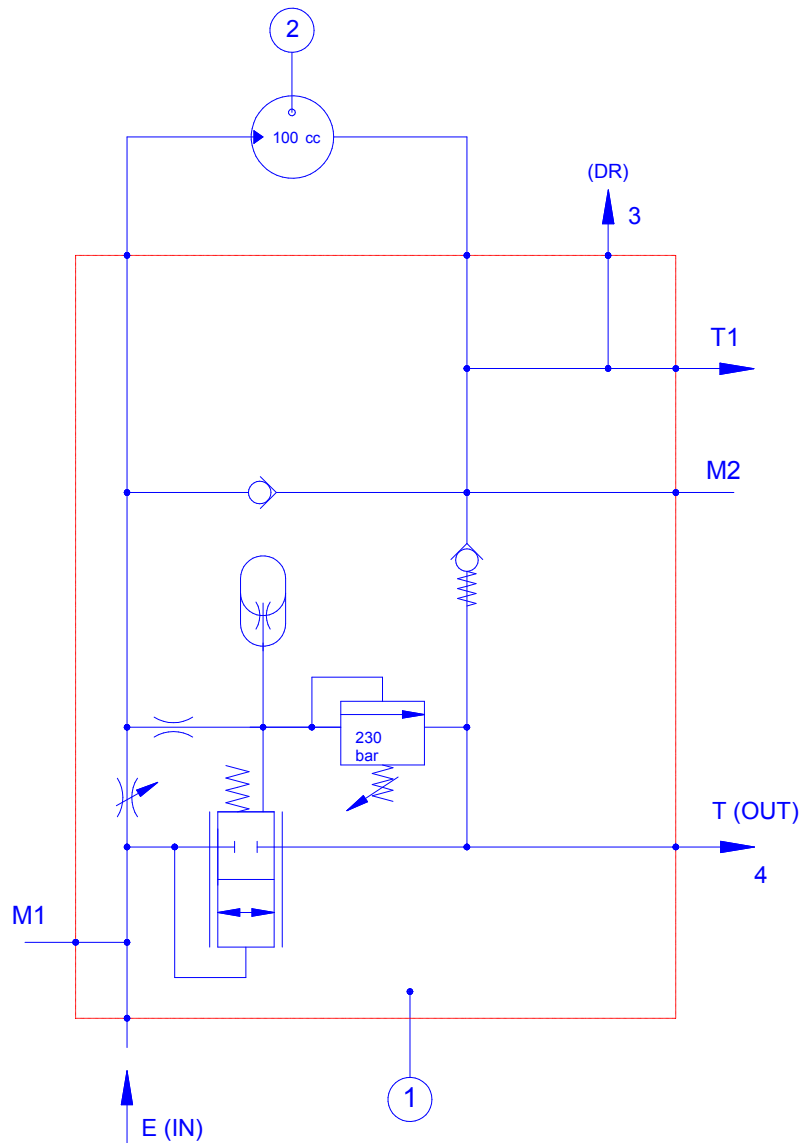

REF.	NAME
1	Capacity regulator group - Maximum output pressure valve 230 bar - Maximum capacity 280 litri/1" - Minimum working capacity 220 litri/1"
2	Hydraulic Motor 100 cc.
T1	Oil drain safety
M1	Output pressure control hold
M2	Return counter pressure control hold
3	Drain (maximum return counter pressure 10 bar)
4	Maximum return counter pressure 10 bar

CRUSHER BUCKET (MB-C50) HYDRAULIC SCHEME cod. MBC50S001

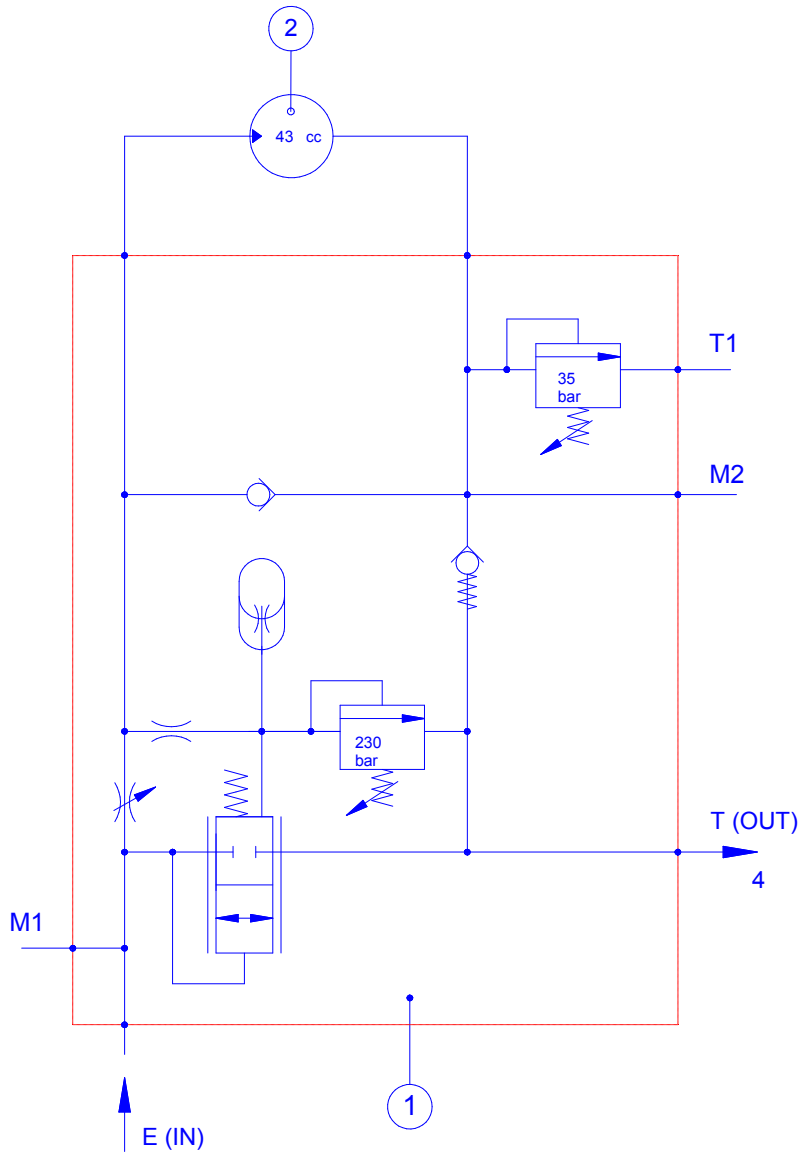

REF.	NAME
1	Capacity regulator group - Maximum output pressure valve 230 bar - Maximum return pressure valve 35 bar - Maximum capacity 140 litri/1" - Minimum working capacity 90 litri/1"
2	Hydraulic Motor 43 cc.
T1	Oil drain safety
M1	Output pressure control hold
M2	Return counter pressure control hold
4	Maximum return counter pressure 10 bar

CRUSHER BUCKET (BF 60) HYDRAULIC SCHEME cod. MF60S0001

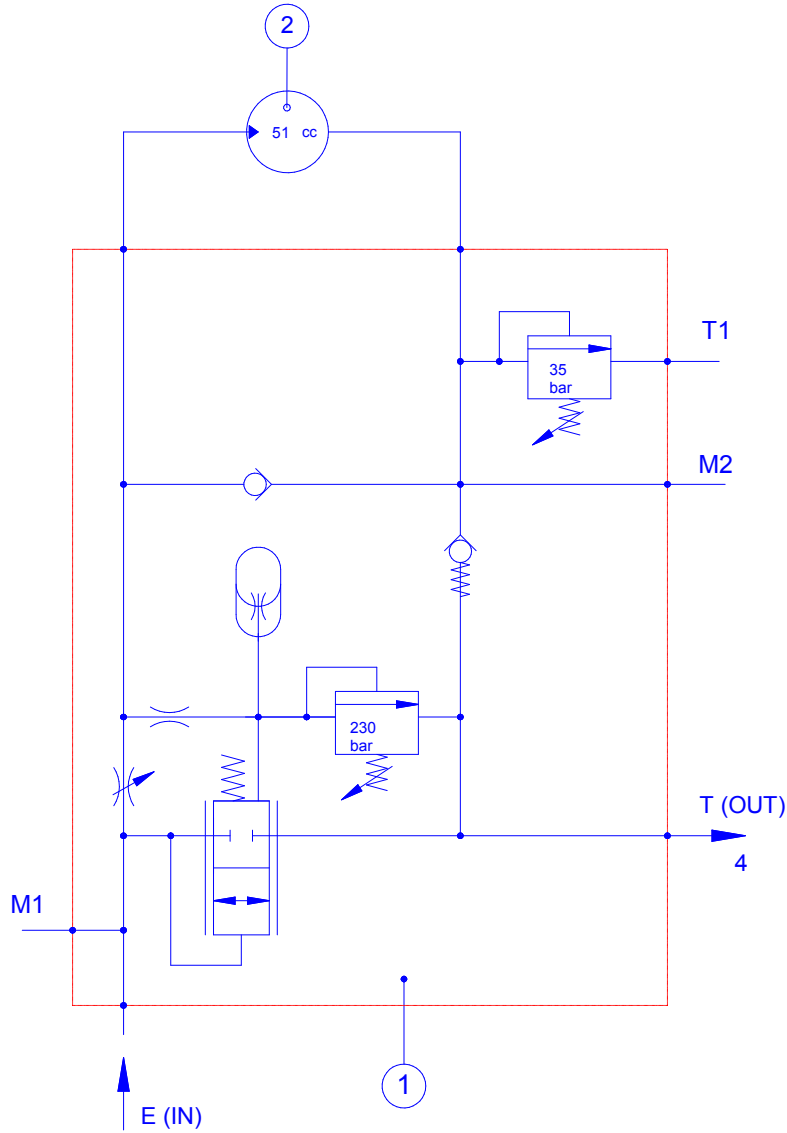

REF.	NAME
1	Capacity regulator group - Maximum output pressure valve 230 bar - Maximum return pressure valve 35 bar - Maximum capacity 280 litri/1" - Minimum working capacity 98 litri/1"
2	Hydraulic Motor 51 cc.
T1	Oil drain safety
M1	Output pressure control hold
M2	Return counter pressure control hold
4	Maximum return counter pressure 10 bar

CRUSHER BUCKET (BF 70)
HYDRAULIC SCHEME cod. MF70S0001

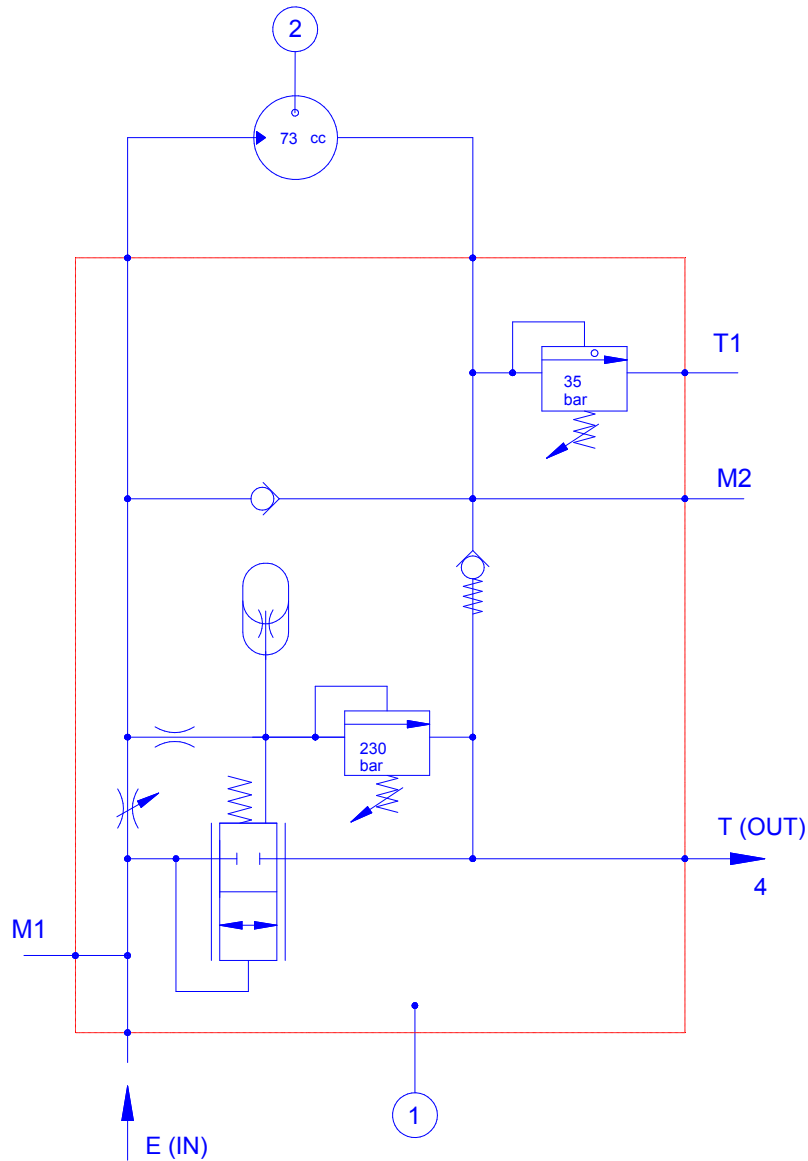

REF.	NAME
1	Capacity regulator group - Maximum output pressure valve 230 bar - Maximum return pressure valve 35 bar - Maximum capacity 280 litri/1" - Minimum working capacity 130 litri/1"
2	Hydraulic Motor 73 cc.
T1	Oil drain safety
M1	Output pressure control hold
M2	Return counter pressure control hold
4	Maximum return counter pressure 10 bar

CRUSHER BUCKET (BF 90 S2) HYDRAULIC SCHEME cod. MF90S0001

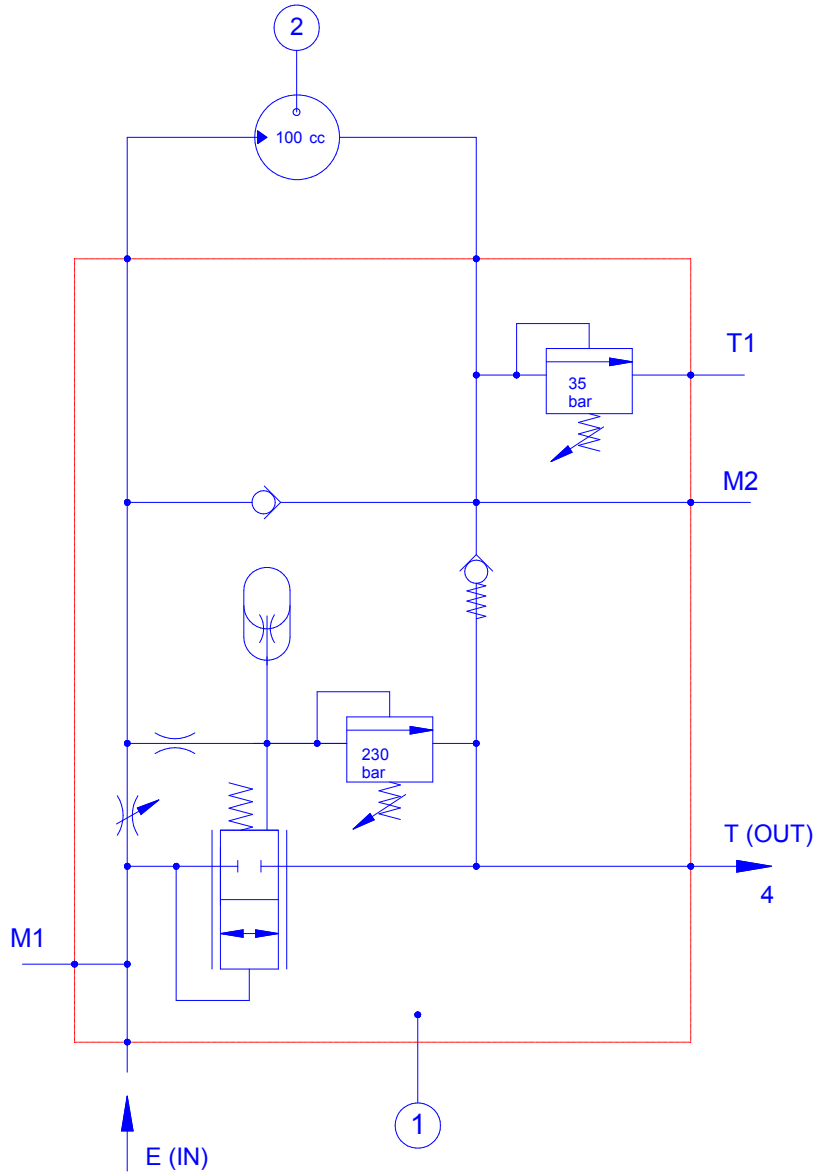

REF.	NAME
1	Capacity regulator group - Maximum output pressure valve 230 bar - Maximum return pressure valve 35 bar - Maximum capacity 280 litri/1" - Minimum working capacity 170 litri/1"
2	Hydraulic Motor 100 cc.
T1	Oil drain safety
M1	Output pressure control hold
M2	Return counter pressure control hold
4	Maximum return counter pressure 10 bar

CRUSHER BUCKET (BF 120 S2) HYDRAULIC SCHEME cod. MF120S0001

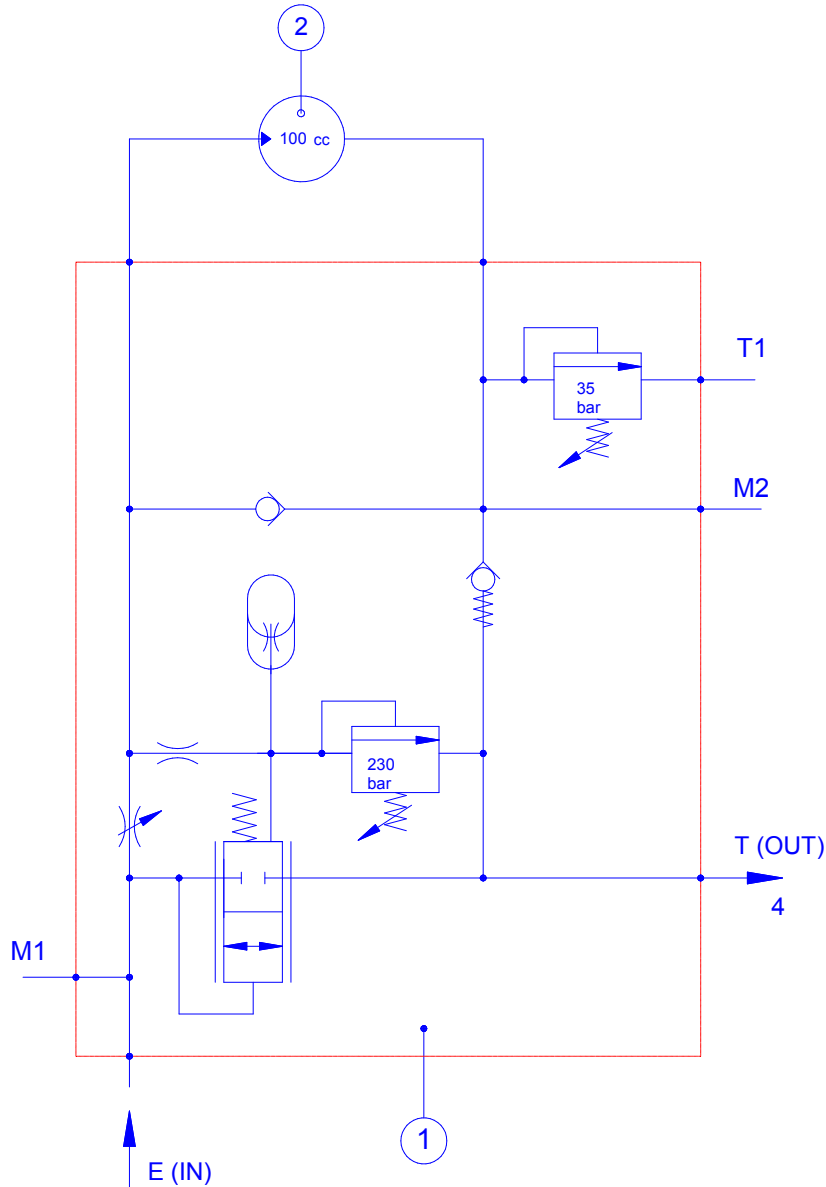

REF.	NAME
1	Capacity regulator group - Maximum output pressure valve 230 bar - Maximum return pressure valve 35 bar - Maximum capacity 280 litri/1" - Minimum working capacity 220 litri/1"
2	Hydraulic Motor 100 cc.
T1	Oil drain safety
M1	Output pressure control hold
M2	Return counter pressure control hold
4	Maximum return counter pressure 10 bar



MB-C50 - BF60.1 - BF70.2 - BF90.3 S2 - BF90.3 S2 HD - BF120.4 S2 - BF120.4 S2 HD



MB S.p.A.

Via Astico, 30/A - 36030 Fara Vicentino (VI) Italia
Tel: 0039 0445 308148 - Fax: 0039 0445 308179
www.mbcruiser.com - Mail: info@mbcrusher.com